

Impedance spectroscopy of vanadium modified BaBi₂Nb₂O₉ ceramics^{*}

Malgorzata Adamczyk^{1,a}, Lucjan Kozielski¹, Dariusz Bochenek¹, Daria Radoszewska¹, Marian Pawelczyk², and Beata Wodecka-Dus¹

¹ Institute of Technology and Mechatronics, University of Silesia, 12, Źytunia St., 41-200 Sosnowiec, Poland

² Institute of Information Technologies, ul. Mickiewicza 29, 40-085 Katowice, Poland

Received 22 May 2015 / Received in final form 14 September 2015

Published online 10 February 2016

© The Author(s) 2016. This article is published with open access at Springerlink.com

Abstract. In recent years a wide range of Aurivillius layered materials have been introduced. These novel materials are produced in many various forms such as fibers, thin films as well as bulk by using a number of processing routes. As advanced materials they are they have many interesting properties which include a number of useful electrical properties related to separated grain and grain boundary conductivity, impedance, activation energies, etc. In this paper these properties are described and discussed in detail. The electrical properties of the vanadium doped BaBi₂Nb₂O₉ ceramic was measured over a wide range of temperatures by impedance spectroscopy (IS). The separated grain activation energy, calculated from Arrhenius characteristics at temperatures between room temperature and 600 °C, was 1 eV for 0 at.% of vanadium dopant and 1.2 eV for 10 at.%, whereas the activation energies in the grain boundary region were 0.97 and 1.15 eV, respectively. The obtained results suggest the significant role of vanadium dopant, causing ordering the crystalline structure.

1 Introduction

In the past years the development of non-volatile random accesses memories (NVRAMs) based on lead-containing thin film was observed. The most popular ceramic material in such applications was, and still is, PbZrO₃ [1] (and its modifications by strontium, barium and niobium) [2,3] due to its non-volatility, large remanent polarization, fast switching speed and radiation hardness [4]. However, one of the most serious damages associated with the Pt/PZT/Pt ferroelectric capacitors is the degradation of the polarization hysteresis characteristic. The layered perovskites belonging to the Aurivillius family might be the solution to that problem, as they meet the requirements for NVRAMs without showing any significant fatigue even after 10¹¹–10¹² switching cycles [5,6]. The BaBi₂Nb₂O₉ thin film is an example of interesting materials, which possess very convenient properties as for application in NVRAMs, namely it is characterized by the high value of permittivity and low value of dielectric loss [4]. Additional advantage of this material is its thermal stability [7] and low value of leakage current [4,7]. Although the discussed material has a drawback: the low remnant

polarization, there is a way to overcome that limitation by modifying the material with admixtures. The literature shows that one of the best elements to be doped is vanadium [8,9]. The V⁵⁺ ions, which partial replace of niobium ions, not only help in obtaining denser material but also improve dielectric and ferroelectric properties of basic ceramics. In the present paper we would like to discuss the influence of vanadium modification on electric properties of BaBi₂Nb₂O₉ ceramics.

2 Materials and method characterization

The pure and vanadium modified BaBi₂Nb₂O₉ ceramics were prepared using the conventional mixed-oxide processing technique starting from stoichiometric amounts of BaCO₃, Bi₂O₃, V₂O₅ and Nb₂O₅. Thermal synthesis of the pressed mixture was carried out at 950 °C for 2 h. Then the materials were crushed, milled and sieved. The second sintering was performed at 1100 °C for 6 h in the case of undoped ceramics. The sintering temperature of ceramics containing vanadium was lowered to 1050 °C and the sintering process lasted for 3 h only.

The Archimedes displacement method with distilled water was conducted to evaluate the sample density. The bulk density of pure BBN ceramics was 7.07 g/cm³ (97% of theoretical density) and gradually increased with the

^{*} Contribution to the Topical Issue “Materials for Dielectric Applications”, edited by Maciej Jaroszewski and Sabu Thomas.

^a e-mail: malgorzata.adamczyk-habrajska@us.edu.pl

Table 1. The theoretical and experimental (evaluated with the EDS analysis) concentration of Ba, Bi and Nb.

Compound	Stoichiometry	Ba [%]	Bi [%]	Nb [%]	V [%]
BaBi ₂ Nb ₂ O ₉ +1% at. V	theoretical	20	40	39.6	0.4
	real	20.46	39.35	39.81	0.38
BaBi ₂ Nb ₂ O ₉ +5% at. V	theoretical	20	40	38	2
	real	20.98	38.8	38.4	1.72
BaBi ₂ Nb ₂ O ₉ +10% at. V	theoretical	20	40	36	4
	real	19.6	40.2	36.35	3.85

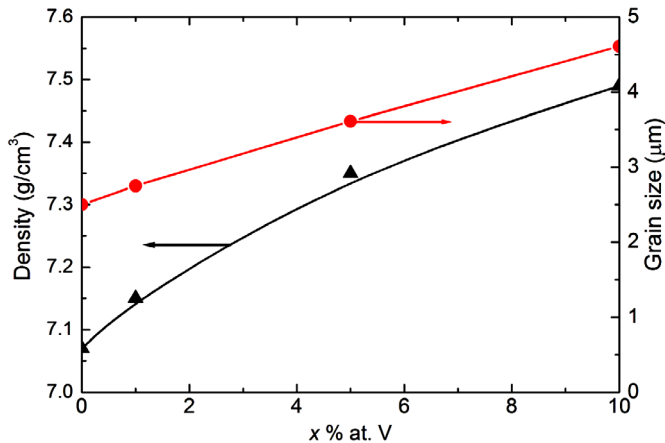
**Fig. 1.** Density and average grain size of vanadium modified BBN ceramics.

increasing of the vanadium content (see Fig. 1). The microstructure of investigated ceramics was examined using the scanning electron microscope (SEM), JSM-5410. The measurements were performed on the ceramics fracture surface. An analysis of the obtained results indicate that with the change of vanadium concentration from 0 to 10 at.% the average grain size increases linearly from 2.5 up to 4.61 μm (see Fig. 1).

The distribution of individual elements within the grains was checked by using the energy dispersion X-ray spectrometer (EDS). The analysis indicated a homogeneous distribution of all elements, apart from oxygen, within the grains of the discussed ceramics. Moreover the quantitative microanalysis performed with the implementation of ISIS-300 SEMQuant programs (Oxford Instruments) showed that all samples had the stoichiometry close to nominal (see Tab. 1).

The samples of 0.6 mm thickness were cut and polished. Subsequently the gold electrodes were deposited on them by cathode sputtering. Next the samples were deaged by thermal treatment at 450 $^{\circ}\text{C}$ prior to measurements to allow recombination and relaxation of part of the frozen defects, formed during the sintering process. Impedance data as a function of temperature was obtained in the 5 Hz–13 MHz frequency range using an HP 4192A impedance analyser in temperature ranging from 400 $^{\circ}\text{C}$ to 600 $^{\circ}\text{C}$. The coherence of obtained data was confirmed by Kramers-Kroning (K-K) validation test [10,11], and data fitting was carried out using the ZView equivalent circuit software produced by Scribner Associates¹.

¹ Scribner Associates, Southern Pines, North Carolina, USA.

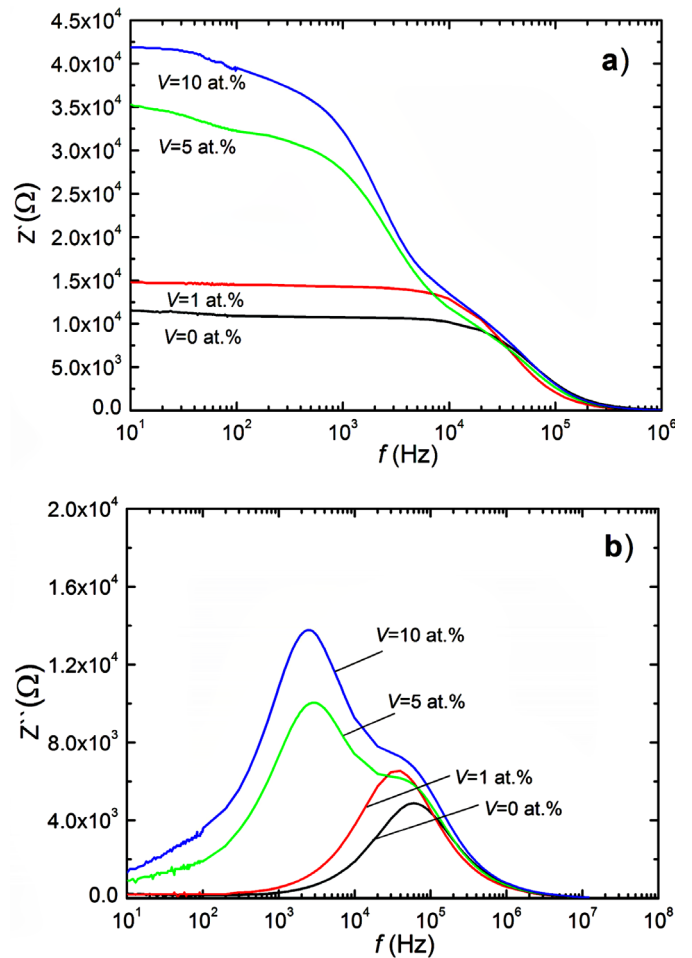
**Fig. 2.** The frequency dependence of real (a) and imaginary (b) part of the impedance at 500 $^{\circ}\text{C}$ for pure and vanadium doped BaBi₂Nb₂O₉ ceramics.

3 Results and discussion

The frequency dependence of real (Z') and imaginary (Z'') part of complex impedance at 500 $^{\circ}\text{C}$ for pure and vanadium modified ceramics is shown in Figure 2. Insertion of 1 at.% of vanadium to BBN ceramics resulted in an increase of the Z' value in the low frequencies. For the low range of frequency, up to 2.5 kHz, the Z' ($\log f$) function stay constant, as it was in the case of pure BBN ceramics [12]. The tendency changed radically in the case of ceramics with bigger vanadium content, as the value of Z'

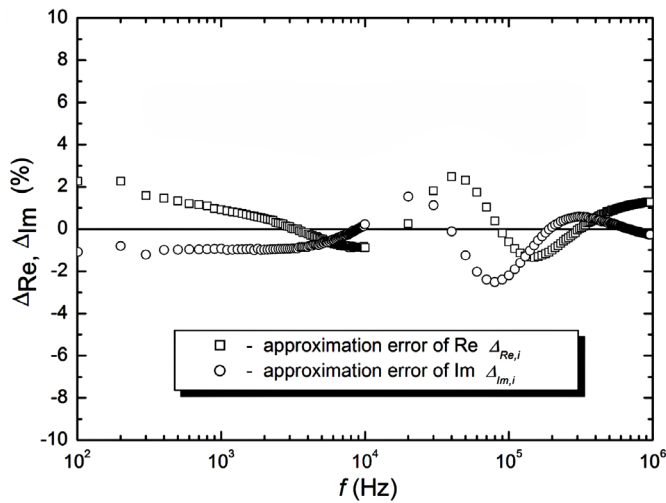

Fig. 3. Display of the Kramers – Kronig test residuals for the measured IS data of pure BBN ceramics as example in temperature 550 °C.

significantly increase and the Z' ($\log f$) dependence is a decreasing function in the investigated frequency range. Increasing vanadium concentration also causes the increase of Z'' ($\log f$) maximum value and shifts the frequency of that value to the lower range. The Z'' maximum has a broadened character and its frequency is temperature dependent. Moreover the full width at half maximum (FWHM) is bigger than 1.4 decade, which points to the deviation from ideal Debye behaviour [13]. It should be emphasized that the value of FWHM increases with the increase of vanadium concentration.

Before starting further detailed analysis of the obtained results the most important fact is whether the given spectra really represents the impedance (proportionality coefficient between related electric potential and current). In the present study the analysis by the K-K relations has been used to validate the data with the use of the computer program by Boukamp [10,11]. Results of residuals for characteristics of BBN ceramics modified by 1 at.% of vanadium, measured at 550 °C, as an example, are given in Figure 3. The distribution of the residuals around the frequency axis is random and the values of $\Delta Re,i, \Delta Im,i$ does not exceed 2%. It indicates that the impedance data are K-K compliant. It is worth mentioning, that for the remaining characteristics the results of K-K test were similar.

The main purpose of this paper is explanation of the materials physical phenomena, especially the contribution of electric properties of various microscopic elements such as grain, grain boundary and interface to total electric conductivity. The goal was achieved by fitting of an adequate equivalent circuit. The first and most important step was to identify the most appropriate equivalent circuit. This goal was achieved by the visual inspection of the data presented as a complex plot between the real and imaginary parts of impedance, in chosen temperature range: 400–580 °C (Fig. 4).

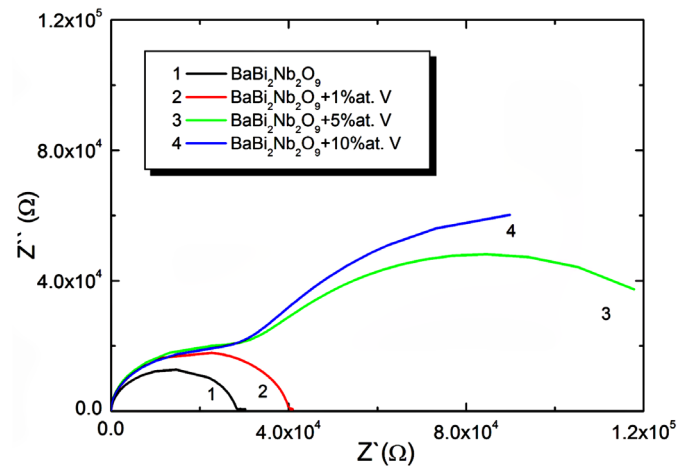

Fig. 4. Complex impedance plots obtained for pure and vanadium modified BaBi₂Nb₂O₉ ceramics.

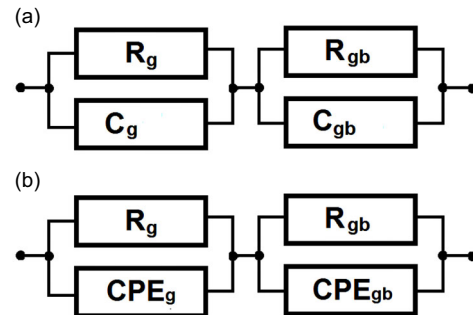

Fig. 5. Equivalent circuit used to represent the impedance response of (a) pure BBN ceramics and 1 at.% of vanadium modified BBN ceramics (b) 5 and 10 at.% of vanadium modified BBN ceramics.

The evolution of the shape of the semicircle can be observed as a function of vanadium content. It is characterized by two main features: increase of the total resistivity and a progressive distortion towards a two-semicircle shape. It is commonly known that the data of AC impedance measurements may be alternatively presented in terms of equivalent circuit. There is no a priori method to find the best equivalent circuit. For a given data set, it is always possible to find more than one equivalent circuit model that can fit the data. Usually, the complex impedance diagram in such form as presented in Figure 4 has been modelled using an equivalent circuit consisting of two parallel resistance-capacitance (RC) elements connected in series (Fig. 5a). The respective elements can be attributed to the contribution of electric properties from the grain and grain boundary [14]. The circuit was very useful to describe the behaviour of pure and 1 at.% doped vanadium ceramics. In case of ceramic with vanadium content of 5 at.% and 10 at.% the proposed diagram was modified, namely both capacitances were replaced by constant phase elements (CPE) (Fig. 5b). This type of replacement is often used in analysis of solid state electric response.

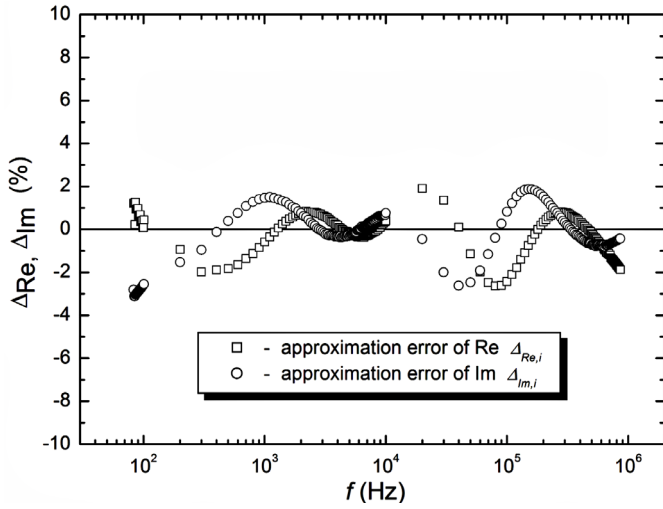

Fig. 6. Fit quality plot obtained for $\text{BaBi}_2\text{Nb}_2\text{O}_9 + 10\%$ at. of vanadium at temperature 560°C .

Table 2. Values of grain and grain boundary resistivity obtained at 500°C .

$x\%$ at. V	R_G (Ω)	R_{GB} (Ω)
0	4198	23 338
1	6199	32 701
5	27 026	104 410
10	29 037	123 810

The CPE is an empirical impedance function with considerable importance in data fitting. It substitutes the uniquely capacitive element, in order to account for the depression of the semicircles when the sample presents a non-Debye behaviour [14,15]. In our opinion the explanation of reasons for changing the equivalent circuit diagram for threshold of vanadium is connected with the changes in microstructure, together with the change of vanadium concentration from 0 to 10 at. % the average grain size increase in $2\ \mu\text{m}$. So the changing percentage share grains and grain boundaries in the volume of the sample.

The fitting of obtained IS results performed using the complex nonlinear least squares method (CNLS) and allowed us to determine the temperature dependence of grain and grain boundary resistivity, which increased with the content of vanadium in sample (Tab. 2).

The quality of the parameter fit of an equivalent circuit to a set of impedance data can be seen in a fit quality plot [16,17] in which the relative deviations of the real (ΔR_e) and imaginary part (ΔI_m) of the impedance are plotted against frequency in a logarithmic scale. For good fit these deviations should be distributed randomly around the frequency axis. In our research a clear sinusoidal-type trace is seen in each case. The example of such dependence is given in Figure 6.

The $\ln R_g$ and $\ln R_{gb}$ as a function of temperature have linear character, which indicates activation character of conductivity process (Fig. 7).

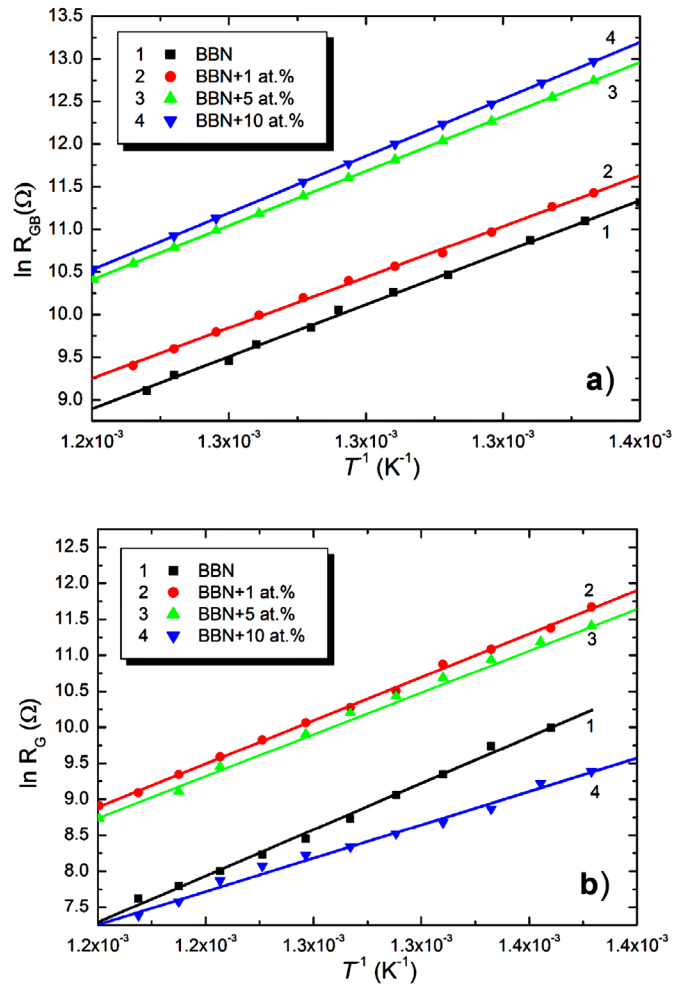

Fig. 7. Arrhenius plots for calculation of conduction activation energies of grain (a) and grain boundary (b).

The linear character of those dependencies proves that the process can be described by formula:

$$R = R_o \exp(-E_a/kT). \quad (1)$$

The directional coefficient of linear equation allows one to estimate the activation energy of grain and grain boundary conductivity for all of discussed samples. The energy increases with the increase of vanadium admixture (Fig. 8).

It is commonly known that the $\text{BaBi}_2\text{Nb}_2\text{O}_9$ ceramics are characterized by local disorder in crystal lattice. As first the assumption was given by Smolensky et al. [18] and next confirmed by Blake et al. [19]. The barium ions show tendency to incorrectly built into crystal lattice, namely incorporate into the Bi_2O_2 layers in place of bismuth ions or in the inter-nodal position. Such scenario is connected with the creation of new point defects. Taking into consideration the results of investigations of defects chemistry of SBN ceramics proposed by Palanduz and Smyth [6,20,21], it can be assumed that simple exchange of barium and bismuth cations resulted in the presence of Ba'_{Bi} acceptor centers in Bi-layer, and $\text{Bi}^\bullet_{\text{Ba}}$ donor centers in the

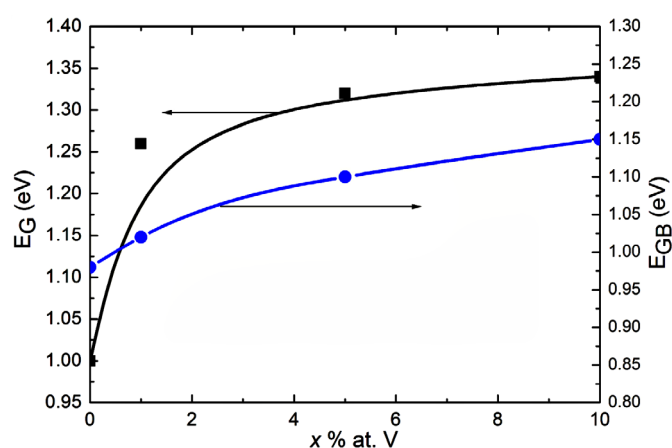

Fig. 8. The activation energy of grain and grain boundary vs. concentration of vanadium admixture.

perovskite-like layers. In an isotropic structure such place of exchange should be self-compensating, and no other defects would be required for charge balance. But in case of layered structure the self-compensation process was not fully effective and there was a significant amount of charge compensation within each layer. Thus Ba'_{Bi} acceptor centers in the Bi layer can be partially compensated by oxygen vacancies, $\text{V}_{\text{O}}^{\bullet\bullet}$ or holes, h^{\bullet} , while the $\text{Bi}^{\bullet}_{\text{Ba}}$ donor centers in the perovskite layers can be partially compensated by cation vacancies V''_{Ba} or electrons e' . Incorporation of vanadium additive caused the ordering of crystal structure. Thus taking into account the difference in the ionic radius of vanadium and niobium ions one would expect significant changes in the size of the lattice parameters. However the results widely described in our previous paper [22] revealed, that the observed changes of lattice parameter were much smaller than we expected. The shrinking of the unit cell, connected with the small radius value of vanadium ions, is restrained by $(\text{Bi}_2\text{O}_2)^{+2}$ layers [8]. The free space, which is created in lattice unit cell, encourages to the proper incorporation of the barium ions. The adequate incorporation of Ba^{+2} leads to the reduction of the number of defects in material. The consequence of such scenario is an increase of grain and grain boundary resistivity, as well as the energy activation value.

4 Conclusion

The impedance behaviour of vanadium modified ceramics was investigated over wide frequency and temperature range. Basing on obtained results the temperature dependence of grain and grain boundary resistivity were obtained. The linear character of that dependences indicates the activation character of the conductivity process in both constituents of microstructure. Vanadium dopant causes an increase in grain and grain boundary resistivity

as well as activation energy, which is connected with decrease of conductivity of samples.

Taking into the consideration the presented results and the ionic radius of vanadium and niobium, it could be said that the admixture of vanadium orders the crystal structure of ceramics which is closely connected with the decrease of space charge concentration and conductivity.

This work was supported by grant NN 507504338 from the Ministry of Science and Higher Education of Poland.

References

1. G. Akcay, S.P. Alpay, G.A. Rossetti, J.F. Scott, *J. Appl. Phys.* **103**, 024104 (2008)
2. X. Hao, J. Ziai, J. Zhou, Z. Yue, J. Yang, W. Zhao, S. An, *J. Alloys Compd.* **509**, 271 (2011)
3. N. Ikeda, A. Kamegawa, H. Takamura, M. Okada, *Mater. Trans.* **41**, 589 (2000)
4. A. Laha, S.B. Krupanidhi, *Appl. Phys. Lett.* **77**, 3818 (2000)
5. E.C. Subbarao, *J. Phys. Chem. Solids* **23**, 665 (1962)
6. C.A. Palanduz, D.M. Smyth, *J. Eur. Ceram. Soc.* **19**, 731 (1999)
7. A. Laha, S.B. Krupanidhi, *J. Appl. Phys.* **92**, 415 (2002)
8. Y. Wu, Ch. Nguyen, S. Seraji, M. Forbess, S.J. Limmer, T. Chou, G. Cao, *J. Am. Ceram. Soc.* **84**, 2882 (2001)
9. B.J. Kalaiselvi, R. Sridarane, R. Murugan, *Ceram. Int.* **32**, 467 (2006)
10. B.A. Boukamp, *J. Electrochem. Soc.* **142**, 1885 (1995)
11. B. Boukamp, *Solid State Ionics* **169**, 65 (2004)
12. M. Adamczyk, L. Kozielski, M. Pilch, *Ferroelectrics* **417**, 1 (2011)
13. J.R. Macdonald, *Spectrochimica Acta* **33**, 725 (1988)
14. G.M. Christie, F.P.F. van Berkel, *Solid State Ionics* **83**, 17 (1996)
15. A. Lasia, in *Modern Aspects of Electrochemistry*, edited by B.E. Conway, R.E. White (Kluwer Academic Publishers, New York, 2002), Vol. 35, p. 1
16. B. Boukamp, *Solid State Ionics* **20**, 31 (1986)
17. B. Boukamp, *Solid State Ionics* **18-19**, 136 (1986)
18. G.A. Smolensky, V.A. Isupov, A.I. Agranovskaya, *Sov. Phys. Solid State* **3**, 651 (1961)
19. S.M. Blake, M.J. Falconer, M. McCreedy, P. Lightfoot, *J. Mater. Chem.* **7**, 1609 (1997)
20. A.C. Palanduz, D.M. Smyth, *J. Electroceram.* **5**, 21 (2000)
21. A.C. Palanduz, D.M. Smyth, *J. Electroceram.* **11**, 191 (2003)
22. M. Adamczyk, L. Kozielski, M. Pilch, M. Pawelczyk, A. Soszyński, *Ceram. Int.* **39**, 4589 (2013)

Open Access This is an open access article distributed under the terms of the Creative Commons Attribution License (<http://creativecommons.org/licenses/by/4.0>), which permits unrestricted use, distribution, and reproduction in any medium, provided the original work is properly cited.