

Point Discharge Current During a Solar Eclipse

S. S. De · Suman Paul · S. Barui · P. Hazra · D. Kala ·
D. K. Haldar · A. Ghosh · G. Guha

Received: 26 February 2013 / Accepted: 21 September 2013 / Published online: 15 October 2013
© Springer Science+Business Media Dordrecht 2013

Abstract The effect of solar eclipse of July 22, 2009, obscuring up to 91 %, upon the value of point discharge current (PDC) has been reported in this paper. The observation had been taken from Kolkata (Lat. 22.56°N, Long. 88.5°E). During the eclipse period, significant variations in the magnitude of PDC were observed than their average value for the same period in other days. The average value of the PDC for the successive ± 10 days adjacent to the solar eclipse day was about 2.253 A.U. (Arbitrary Unit), while the minimum value showed about 2.242 A.U. at the time of greatest phase at 06:26.4 IST (Indian Standard Time). The results are mainly interpreted in terms of changes of the conductivity of the medium during the solar eclipse.

Keywords Atmospheric leakage current · Vertical electric potential gradient · Solar eclipse · Non-linearity in the lower atmosphere

1 Introduction

In the tropical ($\pm 25^\circ$) and temperate ($\pm 60^\circ$) latitudes, the variations of electric field, current density, conductivity, relative humidity (RH) and air-temperature over the surface of the Earth are much dependent on global thunderstorm and lightning activities, solar radiations and the concentration of aerosols in the lower ionosphere. The point discharge current (PDC) at the lower region of the atmosphere varies in accordance with the magnitude of the vertical potential gradient (PG) of the atmosphere and its columnar resistance. The generation of potential difference between the Earth's surface and the lower region of the ionosphere is due to the total occurrences of thunderstorm and lightning thunderclouds acting together at any time over the globe. It controls PDC downward from near ground

S. S. De (✉) · S. Paul · S. Barui · P. Hazra · D. Kala · D. K. Haldar · A. Ghosh · G. Guha
S. K. Mitra Centre for Research in Space Environment, Institute of Radio Physics and Electronics,
University of Calcutta, 1, Girish Vidyaratna Lane, Kolkata 700 009, India
e-mail: de_syam_sundar@yahoo.co.in

atmosphere to the Earth's surface. Few reports with various aspects in relation to the PDC are available (Kirkman and Chalmers 1957; Kamra and Varshneya 1967; Jhavar 1968; Stromberg 1971; Rao and Patnaik 1973; Ette and Utah 1973; Rao and Ramanadham 1979; Rao and Nizamuddin 1982; Kamra 1989; Marcz and Bencze 1998). The studies of solar eclipse effect on point discharge current are scanty.

But, there remain a good number of works that reported changes in the Earth's near surface vertical electric PG at the time of solar eclipse (Bauer et al. 1919; Bauer 1920; Markson and Kamra 1971; Dolezalek et al. 1972; Anderson and Dolezalek 1972; Dhannorkar et al. 1989; Manohar et al. 1995). The decrease in PG during eclipse is a common feature. The electrical conductivity of air and the air-earth current-density get increased about 10 % above the normal value during the 10 min period following the totality of the eclipse. Measurements by Retalis (1981) during the annular eclipse of the Sun, on April 29, 1976, on the island of Santorini exhibited reduction in the value of PG. Airborne and ground measurements of PG were made by Markson and Kamra (1971) during the total solar eclipse of March 7, 1970 at Norfolk, Virginia. The ground measurements indicated that the PG had the tendency to reduce during and immediately after the eclipse. Kamra et al. (1982) observed decrease in PG during the solar eclipse of February 16, 1980. A study of the impact of a solar eclipse on the ground surface atmospheric electricity had been made by them using observations of surface electrical potential gradient, conductivity, and boundary layer parameters recorded during the total solar eclipse of February 16, 1980 and on a control day at Raichur. Manohar et al. (1995) observed that during the progress of the eclipse, the diminution in the magnitude of PG and the increase in the conductivity were maximum. These were about 60 % and 200 %, respectively, relative to their control day values. Integrated micrometeorological measurements had been conducted during the eclipse of March 29, 2006 at Kastelorizo, a small island within the path of totality and having various degrees of solar obscuration (Founda et al. 2007). The observations showed a dramatic reduction in the incoming global radiation and subsequent pronounced changes in the surface air-temperature with the lowest temperature values occurring about 15 min after the full phase.

Looking towards the atmospheric conditions of a place, conductivity would partly be influenced due to the presence of anthropogenic, aitken particles and other aerosols in the atmosphere, the distribution of PG deviates partly from the Carnegie curve which was actually drawn from the measurements under fair-weather conditions. Takagi (1977), from the analysis of the electric field data on 85 fair-weather days in Pacific Ocean, concluded that factors like columnar resistance, electrical conductivity and its seasonal variations, ionospheric horizontal field and distance from active thunderstorm areas may influence the universal electric field (Carnegie) on a regional scale.

Since with the removal of solar radiation, the ion density and wind velocity are affected, it is expected that the PDC must get disturbed, more specifically decreased, during solar eclipse. The inter-relations among PDC, PG and near-Earth conductivity may be understood by measuring PDC during solar eclipse and then comparing the same with the results of the measured PG during the eclipse. So it becomes essential to study the time evolution of PDC with the progress of solar eclipse.

In this paper, the results of analyses of the observed records of PDC during the solar eclipse on July 22, 2009 over Kolkata (Lat. 22.56°N, Long. 88.5°E) have been presented. The PDC is recorded as transients in the laboratory through data acquisition system and finally viewed in a computer. Significant variations in the magnitude of current during the eclipse period have been observed than their average value for the same period in other

days. The results are interpreted mainly in terms of changes of the conductivity of the medium.

2 Experimental Setup

The continuous measurement of PDC has been made by using a steel wire having diameter 3 mm and length 8 cm, one end of which is made tapered to a sharp edge. The tip of the sharp edge is about 0.02 mm. The other end is soldered to a co-axial cable which is made perfectly insulated by Teflon. The total junction is tightly covered by Teflon insulated wire. The cable is surrounded by thermoplastic polystyrene which is coated by very thin honeycomb winding copper wire. The external surface is kept within the cylindrical plastic cover. This process ensures efficient heat insulation also. The other end of the cable is connected to the receiving system. The total system (with the projected antenna wire-tip) is erected on a wooden support at a height of 8 m from the ground. Proper precautions are taken to avoid any other objects with sharp edges at the site. The transient responses from the tip are amplified. The overall gain of the amplifier is around 40 dB. IC LF356N has been used at the input stage of the amplifier to ensure high input resistance ($\sim 10^{12}$ Ohm) and good signal to noise ratio. The output of the amplifier is recorded at a sample rate of 1 data per sec, through a data acquisition system that uses a PCI 1050, 16 channels 12 bit DAS Card (Dynglog), having 12 bit A/D converter, 16 digital inputs and outputs. One of the input–output channels is used for PDC signal measurement. The recorded data are analyzed through Origin 5.0 software. A set of 15 data have been averaged and then plotted. A block diagram is shown in Fig. 1.

Kestrel[®] 4500 pocket weather tracker measures the wind direction, crosswind, head-wind/tailwind, altitude, pressure trend, barometric pressure. It also measures wet bulb temperature, relative humidity, dew point, density, altitude, air and snow temperature. We measured temperature of near-Earth surface and RH at an interval of 15 min. Well-sealed, precision thermistor is mounted externally and thermally isolated for rapid response to measure temperature with ± 0.5 °C and 0.1 °C resolution. Operational range is -29.0 – 70.0 °C. Relative humidity with ± 3.0 % accuracy and was measured with high resolution. Operational range is 0–100 %. Polymer capacitive humidity sensor is mounted in thin-walled chamber external to the case for rapid and accurate response.

3 Observations

The path of solar eclipse on July 22, 2009 over India is depicted in Fig. 2 which was about 300 km from Kolkata. The solar eclipse started at 05:28.8 IST (Indian Standard Time) and continued up to 07:30.9 IST, obscuring up to 91 % occurred in the experimental place, Kolkata, during the maximum phase of the eclipse. Figure 3 represents the variations of temperature and RH on the day of eclipse between the period of 02:00 IST and 12:00 IST. Black and red curve respectively indicate the temperature and RH variation. At the start of the eclipse, the temperature was 28.4° C that gradually falls to 26.2° C when the eclipse attained its greatest phase at 06:26.4 IST. The RH was 84.8 % at the start and reaches 87.2 % at the greatest phase. The sky was partly cloudy throughout the period but there was no rainfall. Light shower occurred around 09:00 IST which persisted in an irregular manner and continued up to 10:20 IST. The sun was visible after the end of the eclipse till the local sunset. The local sunrise occurred at 05:04 IST and sunset at 18:21 IST.

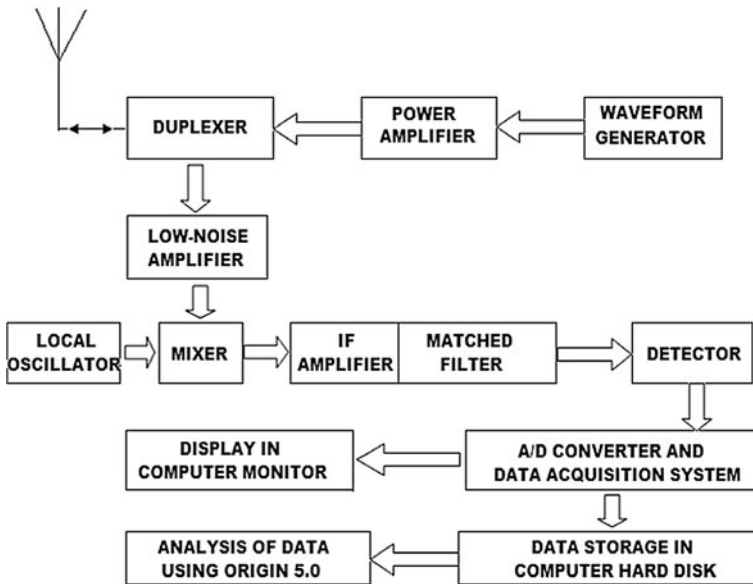

Fig. 1 Block diagram of the receiving system

Diurnal variation of PDC over Kolkata is presented in Fig. 4 during the day of solar eclipse on July 22, 2009 (middle panel). Upper and lower panel indicate the same variation on two control days, i.e., July 21 and 23, 2009, respectively. The value of PDC prior to the eclipse on July 22, 2009 was slightly higher than the average of the adjacent days. It starts to decrease from about 05:30 IST with the commencement of the eclipse and attains the minimum value at about 08:00 IST. The minimum value is about 2.242 A.U. (Arbitrary Unit). The average value of the PDC for the said consecutive days adjacent to the day of solar eclipse is about 2.253 A.U. The typical variations are shown in Table 1. After 08:00 IST, the PDC gradually increases. Subsequently, the nature of the variation is almost similar to that of the two adjacent control days.

4 Discussion

We prepared the Table 1 from the graph of Fig. 4. The diurnal variation of PDC during the eclipse is found to be within the range of 0.5–1 % approximately with respect to the average values of the two adjacent control days (July 21 and July 23, 2009, respectively). We checked the operational condition of the measuring system and found no fault in the recording. The nature of variation gives the actual trend. The data are chosen in Arbitrary Unit. We required the relative change of PDC, for which we did not use the calibration in the measurement of data to avoid the experimental determination of several apparatus constants.

In the absence of solar radiation during eclipse, because of the want of ionization, the PDC drop down suddenly and maintains nearly a plateau with almost fixed value as indicated in Fig. 4 (middle panel) during the period of the eclipse. But as soon as the eclipse seized, solar radiations enhance the causality background rapidly showing the



Fig. 2 The places bounded by *curved lines* are those from where cent percent obscuration was observed during the solar eclipse on July 22, 2009. A maximum obscuration of 91 % was occurred at the position of the observing station, Kolkata

signature of approaching the ambient magnitude of PDC. But, this come-back situation can not be achieved quickly. The total process is highly quasi-static due to which the relaxation time for the process holds a longer value for which the results become asymmetrical at 00:00 IST. It also affected the usual trend of the average value of PDC in other days than the eclipse day during the period of 18:00 to 21:00 IST, the time for recovery effect. Hence, regular sunset effect, as seen from control days, is not present in July 22, 2009 curve.

The curves of PDC in days before and after solar eclipse have very similar character during sunset. It indicates that the measurement of PDC is correct and the day with solar eclipse disturbed equilibrium in the lower atmosphere.

The exact dependence of PDC on various atmospheric parameters, viz., ion density, potential gradient, conductivity, and wind-speed is still unknown. It is, however, granted

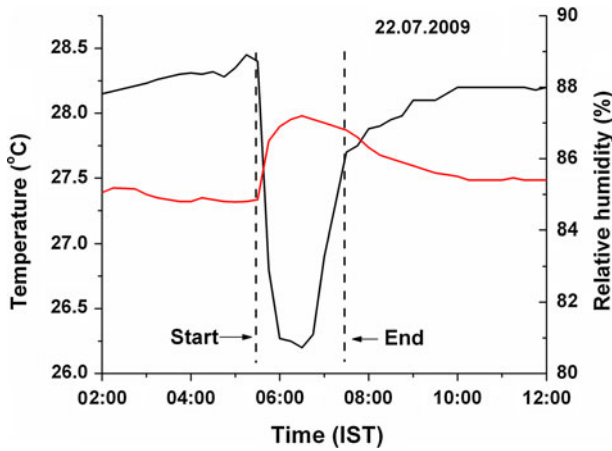

Fig. 3 Temporal variation of temperature (*black coloured curve*) and relative humidity (*red coloured curve*) on July 22, 2009, the day of eclipse between the period of 02:00 IST and 12:00 IST. (Color figure online)

that magnitude of PDC under fair atmospheric condition is dependent at least on two parameters, e.g., potential gradient and wind-speed (Chalmers 1967; Rao et al. 1973; Rao and Nizamuddin 1982). Rao and Nizamuddin (1982) showed that PG and PDC possess the same trend towards the hourly variations over the day. The wind velocity also showed a remarkable correlation with PDC. Wind velocity during the eclipse period takes part in the way of transportation of space charges surrounding the antenna wire-tip causing conductivity of the adjoining medium to fall. As a result, value of PDC decreases. It is now a common belief (Kamra and Varshneya 1967) that for a given height above the Earth's surface, there exists a certain minimum critical potential gradient (E_0), below which no point discharge would take place. According to Chalmers (1967), the simplified formula for point discharge current (I) is given by: $I \propto (E - E_0)W$, where, E is potential gradient and W is the wind-speed. The decrease in potential gradient (E) gives rise to lowering of point discharge current according to Chalmers' formula.

PDC plays an important role to transfer charges from the atmosphere to the Earth. This process shifts the ion concentration above and the surrounding area of the discharge zone (Stromberg 1971) and contributes significantly to the so-called charge balance of the atmosphere. The random migration of ions in the process of transportation enhances the conductivity (Manohar et al. 1995). As Kolkata is a densely populated city surrounded by different industries, it falls under small-scale fair-weather condition where fluctuation of electric field is initiated by ionization and different aerosol contents introducing locally the presence of large number of pollutant particles in air near the surface of the Earth. The collision rate between those particles is greater than pollution free places. So, ions produced in the process are larger in number accumulating near the ground (Kamra et al. 1982). This initiates increase of atmospheric conductivity which in turn causes the diminution of PDC.

Diversity of the nature of variation of current reported in this paper would demonstrate the variability of the curve when averaged over shorter periods. Magnitude of the measured current is comparatively much smaller than that reported earlier (Kamra et al. 1994). When it will be considered on the basis of classical theory of GEC, the reported observations indicate the tendency to accentuate the effect of storm activity over the Asia-Australia,

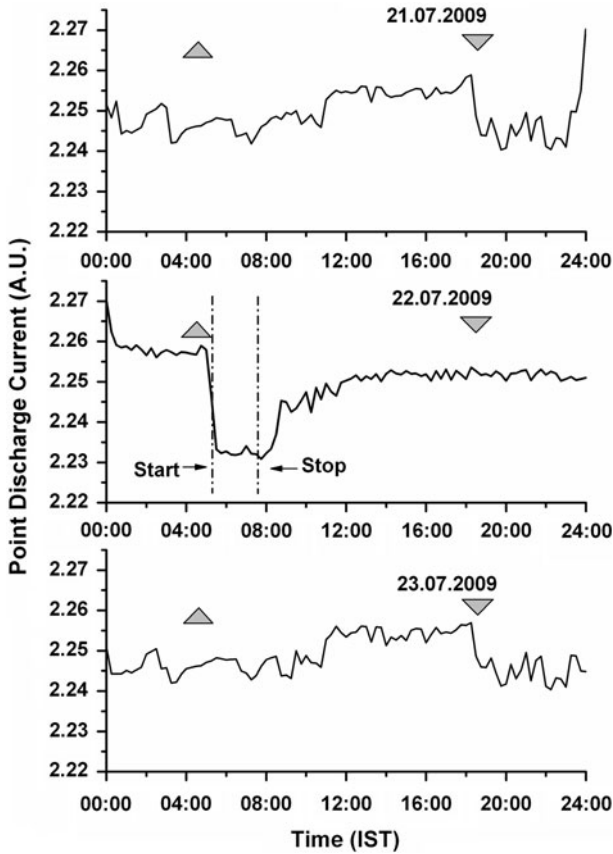

Fig. 4 Temporal variation of point discharge current over Kolkata is presented by the *continuous line curve* during solar eclipse on July 22, 2009 (*middle panel*). The *upper and the lower panel* are for the two control days, July 21 and 23, 2009, respectively. *Upper and lower triangle marks* are for local sunrise and sunset

Table 1 Changes in the values of point discharge current (PDC) during the period of solar eclipse

Fall of PDC at the beginning of the eclipse (A.U.)	Difference of PDC values between the average of the adjacent two control days (July 21 and July 23, 2009) and the eclipse day at the time of commencement (A.U.)	Difference of PDC values between the average of the adjacent two control days (July 21 and July 23, 2009) and the eclipse day at the time of the end of eclipse (A.U.)
0.026	0.015	0.012

Africa, and Europe and to attenuate the effects of far-distant storms over the America. However, small local effects due to existence of atmospheric aerosols can be doubted for the result. Conductivity measurement would be expected to show lower values due to the presence of somewhat higher aerosol particles content in the place of measurement. The possibility of the extension of atmospheric aerosols is not deficient because of almost persistent South-Westerly winds in the monsoon season in this area during the eclipse. The persistence and similarity of variations call for at least regional if not a global effect.

Because of the development of the horizontal potential differences in the ionosphere, the value of PDC at the ground level at this low latitude and in the month of July maintains the low mean value. These may be the reasons for the fluctuation of unitary diurnal variation of the atmospheric electricity parameters.

The meteorological effects may also play some role for the lowering of PDC during eclipse (Anbar 2006; Founda et al. 2007). Atmospheric temperature dropped by 2.2 °C and RH increased by 2.4 % during the period. In the absence of solar radiation during the eclipse, because of the change in the meteorological conditions, particularly enhancement of water vapour, temperature dropped down gradually, thereby ionization and recombination processes get perturbed near the ground and an overall modulation in the space-charge distribution is attained. From the time of the greatest phase, the charge distribution in the perturbed state introduces nonlinearity in the medium. As a result, with the progress of the eclipse, the surface atmospheric turbulence is diminished, for which the near-surface electrical conductivity gets reduced. Hence, PDC values decrease.

It is found that the drop in air-temperature was not analogous to the percentage of obscuration but was principally determined by the surrounding environment (mainly the sea influence), the background meteorological conditions and local cloudiness. Although, we did not measure the wind-speed, aerosol concentration and electric field during the eclipse, it may be conjectured that surface wind-speed would be decreased as a result of the cooling and stabilization of the atmospheric boundary layers. With this view, it is expected that if observation is made over the zone of 100 % obscuration, the potential gradient may reduce to a value very close to its critical value. In such a case, PDC will be too small to be detectable. This fact may also be supported by a fall of wind-speed.

The PDC during solar eclipse over Kolkata manifested themselves in the global structure of Global Electric Circuit (GEC). To justify it, additional measurements of meteorological parameters, ground level aerosol concentration at the time of electrical measurements of the atmosphere would be necessary for interpretation. It will be contemplated in our forthcoming research work.

Acknowledgments This study is supported by Indian Space Research Organization (ISRO) through S. K. Mitra Centre for Research in Space Environment, Institute of Radio Physics and Electronics, University of Calcutta, Kolkata, India. They are thankful to the respected reviewers of this paper for their valuable comments and suggestions, the inclusion of those have sufficiently improved this revised version. The authors are also thankful to Prof. A. Maitra, the Head of the Department of Radio Physics and Electronics, University of Calcutta, for his interest in the problem.

References

- O.M.Y. Anbar, Department of Meteorology, Environment and Arid Land Agriculture, King Abdulaziz University, Jeddah, Soudi Arabia (2006)
- R.V. Anderson, H. Dolezalek, *J. Atmos. Terr. Phys.* **34**, 561–566 (1972)
- L.A. Bauer, H.W. Fisk, S.J. Mauchly, *Terr. Magn. Atmos. Electr.* **24**, 87–98 (1919)
- L.A. Bauer, *Proceedings of National of Science*, October, 6 (1920)
- J.A. Chalmers, *Atmospheric Electricity*, 2nd edn. (Pergamon Press, Oxford, 1967), pp. X, 515
- S. Dhanorkar, C.G. Deshpande, A.K. Kamra, *J. Atmos. Terr. Phys.* **51**, 1031–1034 (1989)
- H. Dolezalek, R.V. Anderson, A.K. Kamra, H.W. Kasemir, D.J. Latham, R. Markson, D.E. Olson, *Archiv für Meteorologie, Geophysik und Bioklimatologie, Serie A* **21**, 221–245 (1972)
- A.I.I. Ette, E.U. Utah, *J. Atmos. Terr. Phys.* **35**, 1799–1809 (1973)
- D. Founda, D. Melas, S. Lykoudis, I. Lisaridis, E. Gerasopoulos, G. Kouvarakis, M. Petrakis, C. Zerefos, *Atmos. Chem. Phys.* **7**, 5543–5553 (2007)
- D.S. Jhavar, *J. Atmos. Terr. Phys.* **30**, 113–123 (1968)

- A.K. Kamra, N.C. Varshneya, J. Atmos. Terr. Phys. **29**, 1519–1527 (1967)
- A.K. Kamra, J.K.S. Teotia, A.B. Sathe, J. Geophys. Res. **87**, 2057–2060 (1982)
- A.K. Kamra, Geophys. Res. Lett. **16**, 127–129 (1989)
- A.K. Kamra, C.J. Deshpande, V. Gopalakrishnan, J. Geophys. Res. **99**, 21043–21050 (1994)
- J.R. Kirkman, J.A. Chalmers, J. Atmos. Terr. Phys. **10**, 258–265 (1957)
- G.K. Manohar, S.S. Kandalgaonkar, M.K. Kulkarni, J. Geophys. Res. **100**, 20805–20814 (1995). doi:[10.1029/95JD01295](https://doi.org/10.1029/95JD01295)
- F. Marcz, P. Bencze, J. Atmos. Sol. Terr. Phys. **60**, 1435–1443 (1998)
- R. Markson, A.K. Kamra, J. Atmos. Terr. Phys. **33**, 1107–1113 (1971)
- A.M. Rao, J.K. Patnaik, Indian J. Radio Space Phys. **2**, 105–106 (1973)
- A.M. Rao, R. Ramanadham, PAGEOPH **117**, 904–912 (1979)
- A.M. Rao, S. Nizamuddin, PAGEOPH **120**, 108–116 (1982)
- D.A. Retalis, J. Atmos. Terr. Phys. **43**, 999–1002 (1981)
- I.M. Stromberg, J. Atmos. Terr. Phys. **33**, 473–484 (1971)
- M. Takagi, On the regional effect in the global atmospheric electric field, in *Electrical Processes in Atmosphere*, ed. by H. Dolezalek, R. Reiter (Darmstadt, Germany, 1977)