



L_∞ Algebras for Extended Geometry from Borchers Superalgebras

Martin Cederwall, Jakob Palmkvist

Division for Theoretical Physics, Department of Physics, Chalmers University of Technology,
412 96 Gothenburg, Sweden. E-mail: martin.cederwall@chalmers.se; jakob.palmkvist@chalmers.se

Received: 24 May 2018 / Accepted: 15 March 2019
Published online: 26 April 2019 – © The Author(s) 2019

Abstract: We examine the structure of gauge transformations in extended geometry, the framework unifying double geometry, exceptional geometry, etc. This is done by giving the variations of the ghosts in a Batalin–Vilkovisky framework, or equivalently, an L_∞ algebra. The L_∞ brackets are given as derived brackets constructed using an underlying Borchers superalgebra $\mathcal{B}(\mathfrak{g}_{r+1})$, which is a double extension of the structure algebra \mathfrak{g}_r . The construction includes a set of “ancillary” ghosts. All brackets involving the infinite sequence of ghosts are given explicitly. All even brackets above the 2-brackets vanish, and the coefficients appearing in the brackets are given by Bernoulli numbers. The results are valid in the absence of ancillary transformations at ghost number 1. We present evidence that in order to go further, the underlying algebra should be the corresponding tensor hierarchy algebra.

Contents

1. Introduction	722
2. The Borchers Superalgebra	723
3. Section Constraint and Generalised Lie Derivatives	728
4. Derivatives, Generalised Lie Derivatives and Other Operators	730
4.1 The derivative	730
4.2 Generalised Lie derivative from “almost derivation”	731
4.3 “Almost covariance” and related operators	733
4.4 More operator identities	733
5. Batalin–Vilkovisky Ghost Actions and L_∞ Algebras	735
6. The L_∞ Structure, Ignoring Ancillary Ghosts	739
6.1 Some low brackets	740
6.2 Higher brackets	742
7. Ancillary Ghosts	745
8. The Full L_∞ Structure	747

8.1	Some low brackets	747
8.2	Higher brackets	749
9.	Examples	754
10.	Conclusions	756

1. Introduction

The ghosts in exceptional field theory [1], and generally in extended field theory with an extended structure algebra \mathfrak{g}_r [2], are known to fall into $\mathcal{B}_+(\mathfrak{g}_r)$, the positive levels of a Borcherds superalgebra $\mathcal{B}(\mathfrak{g}_r)$ [3,4]. We use the concept of ghosts, including ghosts for ghosts etc., as a convenient tool to encode the structure of the gauge symmetry (structure constants, reducibility and so on) in a classical field theory using the (classical) Batalin–Vilkovisky framework.

It was shown in Ref. [3] how generalised diffeomorphisms for E_r have a natural formulation in terms of the structure constants of the Borcherds superalgebra $\mathcal{B}(E_{r+1})$. This generalises to extended geometry in general [2]. The more precise rôle of the Borcherds superalgebra has not been spelt out, and one of the purposes of the present paper is to fill this gap. The gauge structure of extended geometry will be described as an L_∞ algebra, governed by an underlying Borcherds superalgebra $\mathcal{B}(\mathfrak{g}_{r+1})$. The superalgebra $\mathcal{B}(\mathfrak{g}_{r+1})$ generalises $\mathcal{B}(E_{r+1})$ in Ref. [3], and is obtained from the structure algebra \mathfrak{g}_r by adding two more nodes to the Dynkin diagram, as will be explained in Section 2. In cases where the superalgebra is finite-dimensional, such as double field theory [5–19], the structure simplifies to an $L_{n<\infty}$ algebra [20–22], and the reducibility becomes finite.

It is likely that a consistent treatment of quantum extended geometry will require a full Batalin–Vilkovisky treatment of the ghost sector, which is part of the motivation behind our work. Another, equally strong motivation is the belief that the underlying superalgebras carry much information about the models—also concerning physical fields and their dynamics—and that this can assist us in the future when investigating extended geometries based on infinite-dimensional structure algebras.

The first $8 - r$ levels in $\mathcal{B}(E_r)$ consist of E_r -modules for form fields in exceptional field theory [1,23–40], locally describing eleven-dimensional supergravity. Inside this window, there is a connection-free but covariant derivative, taking an element in R_p at level p to R_{p-1} at level $p - 1$ [31]. Above the window, the modules, when decomposed as $\mathfrak{gl}(r)$ modules with respect to a local choice of section, start to contain mixed tensors, and covariance is lost. For E_8 , the window closes, not even the generalised diffeomorphisms are covariant [39] and there are additional restricted local E_8 transformations [38]. Such transformations were named “ancillary” in ref. [2]. In the present paper, we will not treat the situation where ancillary transformations arise in the commutator of two generalised diffeomorphisms, but we will extend the concept of ancillary ghosts to higher ghost number. It will become clear from the structure of the doubly extended Borcherds superalgebra $\mathcal{B}(\mathfrak{g}_{r+1})$ why and when such extra restricted ghosts appear, and what their precise connection to *e.g.* the loss of covariance is.

A by-product of our construction is that all identities previously derived on a case-by-case basis, relating to the “form-like” properties of the elements in the tensor hierarchies [31,41], are derived in a completely general manner.

Although the exceptional geometries are the most interesting cases where the structure has not yet been formulated, we will perform all our calculations in the general setting with arbitrary structure group (which for simplicity will be taken to be simply

laced, although non-simply laced groups present no principal problem). The general formulation of ref. [2] introduces no additional difficulty compared to any special case, and in fact provides the best unifying formalism also for the different exceptional groups. We note that the gauge symmetries of exceptional generalised geometry have been dealt with in the L_∞ algebra framework earlier [42]. However, this was done in terms of a formalism where ghosts are not collected into modules of E_r , but consist of the diffeomorphism parameter together with forms for the ghosts of the tensor gauge transformations (*i.e.*, in generalised geometry, not in extended geometry).

In Section 2, details about the Borchers superalgebra $\mathcal{B}(\mathfrak{g}_{r+1})$ are given. Especially, the double grading relevant for our purposes is introduced, and the (anti-)commutators are given in this basis. Section 3 introduces the generalised Lie derivative and the section constraint in terms of the Borchers superalgebra bracket. In Section 4 we show how the generalised Lie derivative arises naturally from a nilpotent derivative on the $\mathcal{B}(\mathfrak{g}_r)$ subalgebra, and how ancillary terms/ghosts fit into the algebraic structure. Some further operators related to ancillary terms are introduced, and identities between the operators are derived. Section 5 is an interlude concerning L_∞ algebras and Batalin–Vilkovisky ghosts. The non-ancillary part of the L_∞ brackets, *i.e.*, the part where ghosts and brackets belong to the $\mathcal{B}_+(\mathfrak{g}_r)$ subalgebra, is derived in Section 6. The complete non-ancillary variation $(S, C) = \sum_{n=1}^\infty \llbracket C^n \rrbracket$ can formally be written as

$$(S, C) = dC + g(\text{ad } C)\mathcal{L}_C C, \tag{1.1}$$

where g is the function

$$g(x) = \frac{2}{1 - e^{-2x}} - \frac{1}{x}, \tag{1.2}$$

containing Bernoulli numbers in its Maclaurin series. Ancillary ghosts are introduced in Section 7, and the complete structure of the L_∞ brackets is presented in Section 8. Some examples, including ordinary diffeomorphisms (the algebra of vector fields), double diffeomorphisms and exceptional diffeomorphisms, are given in Section 9. We conclude with a discussion, with focus on the extension of the present construction to situations where ancillary transformations are present already in the commutator of two generalised diffeomorphisms.

2. The Borchers Superalgebra

For simplicity we assume the structure algebra \mathfrak{g}_r to be simply laced, and we normalise the inner product in the real root space by $(\alpha_i, \alpha_i) = 2$. We let the coordinate module, which we denote $R_1 = R(-\lambda)$, be a lowest weight module¹ with lowest weight $-\lambda$. Then the derivative module is a highest weight module $R(\lambda)$ with highest weight λ , and $R(-\lambda) = \overline{R(\lambda)}$.

As explained in ref. [3] we can extend \mathfrak{g}_r to a Lie algebra \mathfrak{g}_{r+1} or to a Lie superalgebra $\mathcal{B}(\mathfrak{g}_r)$ by adding a node to the Dynkin diagram. In the first case, the additional node is an ordinary “white” node, the corresponding simple root α_0 satisfies $(\alpha_0, \alpha_0) = 2$, and the resulting Lie algebra \mathfrak{g}_{r+1} is a Kac–Moody algebra like \mathfrak{g}_r itself. In the second case,

¹ In refs. [2,40], the coordinate module was taken to be highest weight module. We prefer to reverse these conventions (in agreement with ref. [3]). With the standard basis of simple roots in the superalgebra, its positive levels consists of *lowest* weight \mathfrak{g}_r -modules. In the present paper the distinction is not essential, since the cases treated all concern finite-dimensional \mathfrak{g}_r and finite-dimensional \mathfrak{g}_r -modules.

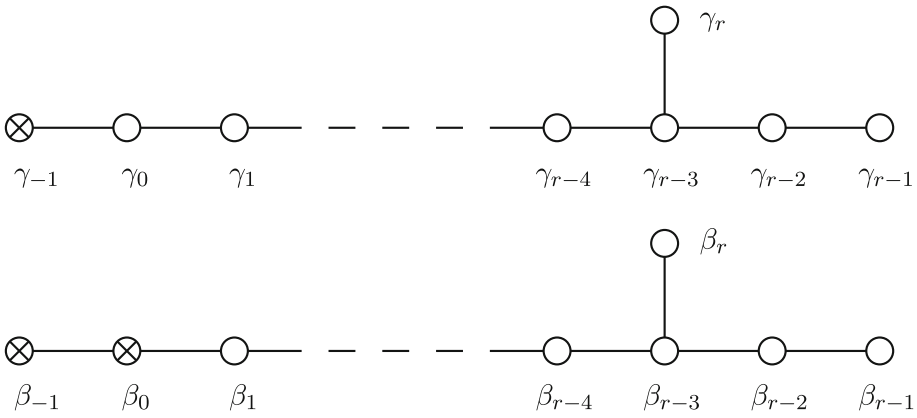

Fig. 1. Dynkin diagrams of $\mathcal{B}(E_{r+1})$ together with our notation for the simple roots represented by the nodes

the additional node is “grey”, corresponding to a simple root β_0 . It satisfies $(\beta_0, \beta_0) = 0$, and is furthermore a fermionic (*i.e.*, odd) root, which means that the associated Chevalley generators e_0 and f_0 belong to the fermionic subspace of the resulting Lie superalgebra $\mathcal{B}(\mathfrak{g}_r)$. In both cases, the inner product of the additional simple root with those of \mathfrak{g}_r is given by the Dynkin labels of λ , with a minus sign,

$$-\lambda_i = -(\lambda, \alpha_i) = (\alpha_0, \alpha_i) = (\beta_0, \beta_i), \tag{2.1}$$

where we have set $\alpha_i = \beta_i$ ($i = 1, 2, \dots, r$).

We can extend \mathfrak{g}_{r+1} and $\mathcal{B}(\mathfrak{g}_r)$ further to a Lie superalgebra $\mathcal{B}(\mathfrak{g}_{r+1})$ by adding one more node to the Dynkin diagrams.² We will then get two different Dynkin diagrams (two different sets of simple roots) corresponding to the same Lie superalgebra $\mathcal{B}(\mathfrak{g}_{r+1})$. These are shown in Figure 1 in the case when $\mathfrak{g} = E_r$ and λ is the highest weight of the derivative module in exceptional geometry. The line between the two grey nodes in the second diagram indicate that the inner product of the two corresponding simple roots is $(\beta_{-1}, \beta_0) = 1$, not -1 as when one or both of the nodes are white.

The two sets of simple roots are related to each other by

$$\gamma_{-1} = -\beta_{-1}, \quad \gamma_0 = \beta_{-1} + \beta_0, \quad \gamma_i = \beta_i. \tag{2.2}$$

This corresponds to a “generalised Weyl transformation” or “odd Weyl reflection” [43], which provides a map between the two sets of Chevalley generators mapping the defining relations to each other, thus inducing an isomorphism.

In spite of the notation $\mathcal{B}(\mathfrak{g}_{r+1})$ we choose to consider this algebra as constructed from the second Dynkin diagram in Figure 1, which means that we let e_0, f_0 and h_0 be associated to β_0 rather than γ_0 . For β_{-1} , we drop the subscript and write the associated generators simply as e, f and h . They satisfy the (anti-)commutation relations

$$[h, e] = [h, f] = 0 \quad [e, f] = h. \tag{2.3}$$

Acting with h on e_0 and f_0 we have

$$[h, e_0] = e_0, \quad [h, f_0] = -f_0. \tag{2.4}$$

² In ref. [2], the algebras $\mathfrak{g}_{r+1}, \mathcal{B}(\mathfrak{g}_r)$ and $\mathcal{B}(\mathfrak{g}_{r+1})$ were called \mathcal{A}, \mathcal{B} and \mathcal{C} , respectively.

Throughout the paper the notation $[\cdot, \cdot]$ is used for the Lie super-bracket of the superalgebra, disregarding the statistics of the generators. Thus, we do not use a separate notation (e.g. $\{\cdot, \cdot\}$, common in the physics literature) for brackets between a pair of fermionic elements.

Let k be an element in the Cartan subalgebra of $\mathcal{B}(\mathfrak{g}_r)$ that commutes with \mathfrak{g}_r and satisfies $[k, e] = e$ and $[k, f] = -f$ when we extend $\mathcal{B}(\mathfrak{g}_r)$ to $\mathcal{B}(\mathfrak{g}_{r+1})$. In the Cartan subalgebra of $\mathcal{B}(\mathfrak{g}_{r+1})$, set $\tilde{k} = k + h$, so that $[e, f] = h = \tilde{k} - k$. We then have

$$\begin{aligned}
 [k, e_0] &= -(\lambda, \lambda)e_0, & [k, e] &= e, \\
 [k, f_0] &= (\lambda, \lambda)f_0, & [k, f] &= -f,
 \end{aligned}
 \tag{2.5}$$

$$\begin{aligned}
 [\tilde{k}, e_0] &= (1 - (\lambda, \lambda))e_0, & [\tilde{k}, e] &= e, \\
 [\tilde{k}, f_0] &= ((\lambda, \lambda) - 1)f_0, & [\tilde{k}, f] &= -f.
 \end{aligned}
 \tag{2.6}$$

The Lie superalgebra $\mathcal{B}(\mathfrak{g}_{r+1})$ can be given a $(\mathbb{Z} \times \mathbb{Z})$ -grading with respect to β_0 and β_{-1} . It is then decomposed into a direct sum of \mathfrak{g}_r modules

$$\mathcal{B}(\mathfrak{g}_{r+1}) = \bigoplus_{(p,q) \in \mathbb{Z} \times \mathbb{Z}} R_{(p,q)},
 \tag{2.7}$$

where $R_{(p,q)}$ is spanned by root vectors (together with the Cartan generators if $p = q = 0$) such that the corresponding roots have coefficients p and q for β_0 and β_{-1} , respectively, when expressed as linear combinations of the simple roots. We will refer to the degrees p and q as *level* and *height*, respectively. They are the eigenvalues of the adjoint action of $h = \tilde{k} - k$ and the Cartan element

$$q = (1 - (\lambda, \lambda))k + (\lambda, \lambda)\tilde{k} = k + (\lambda, \lambda)h,
 \tag{2.8}$$

respectively. Thus

$$[q, e_0] = [q, f_0] = 0, \quad [q, e] = e, \quad [q, f] = -f.
 \tag{2.9}$$

In the same way as the Lie superalgebra $\mathcal{B}(\mathfrak{g}_{r+1})$ can be decomposed with respect to β_0 and β_{-1} , it can also be decomposed with respect to γ_0 and γ_{-1} . Then the degrees m and n , corresponding to γ_0 and γ_{-1} , respectively, are related to the level and height by $m = p$ and $n = p - q$. The L_∞ structure on $\mathcal{B}(\mathfrak{g}_{r+1})$ that we are going to introduce is based on yet another \mathbb{Z} -grading,

$$\mathcal{B}(\mathfrak{g}_{r+1}) = \bigoplus_{\ell \in \mathbb{Z}} L_\ell,
 \tag{2.10}$$

where the degree ℓ of an element in $R_{(p,q)}$ is given by $\ell = p + q$. The L_∞ structure is then defined on (a part of) the subalgebra of $\mathcal{B}(\mathfrak{g}_{r+1})$ corresponding to positive levels ℓ , and all the brackets have level $\ell = -1$. It is important, however, to note that the subset of $\mathcal{B}(\mathfrak{g}_{r+1})$ on which the ghosts live is not closed under the superalgebra bracket, so the space on which the L_∞ algebra is defined will not support a Lie superalgebra structure. The subset in question consists of the positive levels of the subalgebra $\mathcal{B}(\mathfrak{g}_r)$ at $p > 0, q = 0$, together with a subset of the elements at $p > 0, q = 1$. See further Sections 7 and 8. The ghost number is identified with the level $\ell = p + q$ in Table 1.

Following Ref. [3], we let E_M and F^M be fermionic basis elements of $R_{(1,0)} = R_1$ and $R_{(-1,0)} = \bar{R}_1$, respectively, in the subalgebra $\mathcal{B}(\mathfrak{g}_r)$, while \tilde{E}_M and \tilde{F}^M are bosonic basis elements of $R_{(1,1)} = R_1$ and $R_{(-1,-1)} = \bar{R}_1$ in the subalgebra \mathfrak{g}_{r+1} . Furthermore, we

Table 1. The general structure of the superalgebra $\mathcal{B}(\mathfrak{g}_{r+1})$

...	$p = -1$	$p = 0$	$p = 1$	$p = 2$	$p = 3$...
...						$n = 0$
$q = 3$					\tilde{R}_3	$n = 1$
$q = 2$				\tilde{R}_2	$\tilde{R}_3 \oplus \tilde{R}_3$	$n = 2$
$q = 1$		$\mathbf{1}$	R_1	$R_2 \oplus \tilde{R}_2$	$R_3 \oplus \tilde{R}_3$	$n = 3$
$q = 0$	\bar{R}_1	$\mathbf{1} \oplus \text{adj} \oplus \mathbf{1}$	R_1	R_2	R_3	...
...	\bar{R}_1	$\mathbf{1}$		$\ell = 1$	$\ell = 2$	$\ell = 3$

The blue lines are the L_∞ -levels, given by $\ell = p + q$. We also have $m = p$. Red lines are the usual levels in the level decomposition of $\mathcal{B}(\mathfrak{g}_{r+1})$, and form \mathfrak{g}_{r+1} modules. Tables with specific examples are given in Section 9, and use the same gradings as this table

let T_α be generators of \mathfrak{g}_r , and $(t_\alpha)_M^N$ representation matrices in the R_1 representation. Adjoint indices will be raised and lowered with the Killing metric $\eta_{\alpha\beta}$ and its inverse. Then the remaining (anti-)commutation relations of generators at levels $-1, 0$ and 1 in the “local superalgebra” (*i.e.*, where also the right hand side belongs to level $-1, 0$ or 1) that follow from the Chevalley–Serre relations are

$$\begin{aligned}
 [T_\alpha, E_M] &= -(t_\alpha)_M^N E_N, & [T_\alpha, \tilde{E}_M] &= -(t_\alpha)_M^N \tilde{E}_N, \\
 [k, E_M] &= -(\lambda, \lambda) E_M, & [\tilde{k}, \tilde{E}_M] &= (2 - (\lambda, \lambda)) \tilde{E}_M, \\
 [\tilde{k}, E_N] &= (1 - (\lambda, \lambda)) E_N, & [k, \tilde{E}_N] &= (1 - (\lambda, \lambda)) \tilde{E}_N, \\
 [e, E_N] &= \tilde{E}_N, & [e, \tilde{E}_N] &= 0, \\
 [f, E_N] &= 0, & [f, \tilde{E}_N] &= E_N,
 \end{aligned} \tag{2.11}$$

$$\begin{aligned}
 [T_\alpha, F^N] &= (t_\alpha)_M^N F^M, & [T_\alpha, \tilde{F}^N] &= (t_\alpha)_M^N \tilde{F}^M, \\
 [k, F^N] &= (\lambda, \lambda) F^N, & [\tilde{k}, \tilde{F}^N] &= ((\lambda, \lambda) - 2) \tilde{F}^N, \\
 [\tilde{k}, F^N] &= ((\lambda, \lambda) - 1) F^N, & [k, \tilde{F}^N] &= ((\lambda, \lambda) - 1) \tilde{F}^N, \\
 [e, F^N] &= 0, & [e, \tilde{F}^N] &= F^N, \\
 [f, F^N] &= -\tilde{F}^N, & [f, \tilde{F}^N] &= 0,
 \end{aligned} \tag{2.12}$$

$$\begin{aligned}
 [E_M, F^N] &= -(t^\alpha)_M^N T_\alpha + \delta_M^N k, & [\tilde{E}_M, \tilde{F}^N] &= -(t^\alpha)_M^N T_\alpha + \delta_M^N \tilde{k}, \\
 [E_M, \tilde{F}^N] &= \delta_M^N f, & [\tilde{E}_M, F^N] &= -\delta_M^N e.
 \end{aligned} \tag{2.13}$$

From this we get

$$\begin{aligned}
 [[E_M, F^N], E_P] &= f_M^N P^Q E_Q, & [[\tilde{E}_M, \tilde{F}^N], \tilde{E}_P] &= \tilde{f}_M^N P^Q \tilde{E}_Q, \\
 [[E_M, F^N], \tilde{E}_P] &= \delta_M^N \tilde{E}_P + f_M^N P^Q \tilde{E}_Q, & [[\tilde{E}_M, \tilde{F}^N], E_P] &= \delta_M^N E_P + f_M^N P^Q E_Q, \\
 [[E_M, \tilde{F}^N], E_P] &= 0, & [[\tilde{E}_M, F^N], \tilde{E}_P] &= 0, \\
 [[E_M, \tilde{F}^N], \tilde{E}_P] &= \delta_M^N E_P, & [[\tilde{E}_M, F^N], E_P] &= -\delta_M^N \tilde{E}_P,
 \end{aligned} \tag{2.14}$$

where

$$f_M^N P^Q = (t_\alpha)_M^N (t^\alpha)_P^Q - (\lambda, \lambda) \delta_M^N \delta_P^Q, \tag{2.15}$$

and

$$\tilde{f}_M^N P^Q = (t_\alpha)_M^N (t^\alpha)_P^Q + (2 - (\lambda, \lambda)) \delta_M^N \delta_P^Q. \tag{2.16}$$

In particular we have the identities

$$\begin{aligned} [[E_M, F^N], E_P] &= [[\tilde{E}_M, \tilde{F}^N], E_P] + [[E_M, \tilde{F}^N], \tilde{E}_P], \\ [[\tilde{E}_M, \tilde{F}^N], \tilde{E}_P] &= [[E_M, F^N], \tilde{E}_P] - [[\tilde{E}_M, F^N], E_P], \end{aligned} \tag{2.17}$$

which follow from acting with e and f on $[[E_M, \tilde{F}^N], E_P] = 0$ and $[[\tilde{E}_M, F^N], \tilde{E}_P] = 0$, respectively.

Continuing to level 2, the generators E_M and \tilde{E}_M fulfil certain ‘‘covariantised Serre relations’’, following from the Serre relations for e_0 and $[e, e_0]$, the generators corresponding to the roots β_0 and γ_0 , respectively. The Serre relation in the $\mathcal{B}(\mathfrak{g}_r)$ subalgebra states that $[E_M, E_N]$ only spans a submodule R_2 of the symmetric product of two R_1 ’s. The complement of R_2 in the symmetric product is $R(-2\lambda)$, the only module appearing in the square of an object in a minimal orbit. Similarly, the Serre relation in the \mathfrak{g}_{r+1} subalgebra states that $[\tilde{E}_M, \tilde{E}_N]$ only spans \tilde{R}_2 , the complement of which is the highest module in the antisymmetric product of two R_1 ’s. The bracket $[E_M, \tilde{E}_N]$ spans $R_2 \oplus \tilde{R}_2$. The conjugate relations apply to F^M and \tilde{F}^M . We thus have

$$\begin{aligned} [E_M, E_N] &\in R_2, \quad [F^M, F^N] \in \overline{R_2}, \\ [E_M, \tilde{E}_N] &\in R_2 \oplus \tilde{R}_2, \quad [F^M, \tilde{F}^N] \in \overline{R_2} \oplus \overline{\tilde{R}_2}, \\ [\tilde{E}_M, \tilde{E}_N] &\in \tilde{R}_2, \quad [\tilde{F}^M, \tilde{F}^N] \in \overline{\tilde{R}_2}. \end{aligned} \tag{2.18}$$

The modules $\overline{R_2}$ and $\overline{\tilde{R}_2}$ are precisely the ones appearing in the symmetric and antisymmetric parts of the section constraint in Section 3. For more details, *e.g.* on the connection to minimal orbits and to a denominator formula for the Borchers superalgebra, we refer to refs. [2–4]. The (anti-)commutation relations with generators at level ± 1 acting on those in (2.18) at level ∓ 2 follow from Eqs. (2.14) by the Jacobi identity.

An important property of $\mathcal{B}(\mathfrak{g}_{r+1})$ is that any non-zero level decomposes into doublets of the Heisenberg superalgebra spanned by e, f and h . This follows from Eqs. (2.3). An element at positive level and height 0 is annihilated by $\text{ad } f$. It can be ‘‘raised’’ to height 1 by $\text{ad } e$ and lowered back by $\text{ad } f$. We define, for any element at a non-zero level p ,

$$A^\sharp = \frac{1}{p}[A, e], \tag{2.19}$$

$$A^\flat = -[A, f]. \tag{2.20}$$

Then $A = A^\flat + A^\sharp$. Occasionally, for convenience, we will write raising and lowering operators acting on algebra elements. We then use the same symbols for the operators: $\flat A = A^\flat$ and $\sharp A = A^\sharp$.

As explained above $\mathcal{B}(\mathfrak{g}_{r+1})$ decomposes into \mathfrak{g}_r modules, where we denote the one at level p and height q by $R_{(p,q)}$. Every \mathfrak{g}_r -module $R_p = R_{(p,0)}$ at level $p > 0$ and height 0 exists also at height 1. In addition there may be another module. We write

$R_{(p,1)} = R_p \oplus \tilde{R}_p$. Sometimes, \tilde{R}_p may vanish. The occurrence of non-zero modules \tilde{R}_p is responsible for the appearance of ‘‘ancillary ghosts’’.³

Let A and B be elements at positive level and height 0 (or more generally, annihilated by $\text{ad } f$), and denote the total statistics of an element A by $|A|$. The notation is such that $|A|$ takes the value 0 for a totally bosonic element A and 1 for a totally fermionic one. ‘‘Totally’’ means statistics of generators and components together, so that a ghost C always has $|C| = 0$, while its derivative (to be defined in Eq. (4.1) below) has $|dC| = 1$. This assignment is completely analogous to the assignment of statistics to components in a superfield. To be completely clear, our conventions are such that also fermionic components and generators anticommute, so that if e.g. $A = A^M E_M$ and $B = B^N E_N$ are elements at level 1 with $|A| = |B| = 0$, then $[A, B] = [A^M E_M, B^N E_N] = -A^M B^N [E_M, E_N]$. A bosonic gauge parameter A^M at level 1 sits in an element A with $|A| = 1$.

Some useful formulas involving raising and lowering operators are easily derived:

$$[A, B^\sharp]^\flat = [A, B], \tag{2.21}$$

$$[A, B^\sharp]^\sharp = -(-1)^{|B|} (\text{ad } h)^{-1} [[h, A^\sharp], B^\sharp]. \tag{2.22}$$

Note that $[A^\sharp, B^\sharp]$ has height 2 and lies in $\tilde{R}_{p_A+p_B}$, if p_A, p_B are the levels of A, B . The decomposition

$$[A, B^\sharp] = [A, B]^\sharp - (-1)^{|B|} (\text{ad } h)^{-1} [[h, A^\sharp], B^\sharp]^\flat \tag{2.23}$$

provides projections of $R_{(p,1)} = R_p \oplus \tilde{R}_p$ on the two subspaces.

We will initially consider fields (ghosts) in the positive levels of $\mathcal{B}(\mathfrak{g}_r)$, embedded in $\mathcal{B}(\mathfrak{g}_{r+1})$ at zero height. They can thus be characterised as elements with positive (integer) eigenvalues of $\text{ad } h$ and zero eigenvalue of the adjoint action of the element q in Eq. (2.8). Unless explicitly stated otherwise, elements in $\mathcal{B}(\mathfrak{g}_{r+1})$ will be ‘‘bosonic’’, in the sense that components multiplying generators that are fermions will also be fermionic, as in a superfield. This agrees with the statistics of ghosts. With such conventions, the superalgebra bracket $[\cdot, \cdot]$ is graded antisymmetric, $[C, C] = 0$ when $|C| = 0$.

3. Section Constraint and Generalised Lie Derivatives

We will consider elements in certain subspaces of the algebra $\mathcal{B}(\mathfrak{g}_{r+1})$ which are also functions of coordinates transforming in $R_1 = R(-\lambda)$, the coordinates of an extended space. The functional dependence is such that a (strong) section constraint is satisfied. A derivative is in $\bar{R}_1 = R(\lambda)$. Given the commutation relations between F^M and \tilde{F}^M (which both provide bases of \bar{R}_1), the section constraint can be expressed as

$$\begin{aligned} [F^M, F^N] \partial_M \otimes \partial_N &= 0, \\ [F^M, \tilde{F}^N] \partial_M \otimes \partial_N &= 0, \\ [\tilde{F}^M, \tilde{F}^N] \partial_M \otimes \partial_N &= 0. \end{aligned} \tag{3.1}$$

The first equation expresses the vanishing of R_2 in the symmetric product of two derivatives (acting on the same or different fields), the last one the vanishing of \tilde{R}_2 in the

³ The notation \tilde{R}_p was used differently in ref. [3]. There, $\tilde{R}_1, \tilde{R}_2, \tilde{R}_3, \dots$ correspond to $R_1, \tilde{R}_2, \tilde{R}_3, \dots$ here, i.e., the representations on the diagonal $n = 0$ in Table 1. Thus it is only for $p = 2$ that the meanings of the notation coincide.

antisymmetric product, and the second one contains both the symmetric and antisymmetric constraint. The first and third constraints come from the subalgebras $\mathcal{B}(\mathfrak{g}_r)$ and \mathfrak{g}_{r+1} , respectively, which gives a simple motivation for the introduction of the double extension. By the Jacobi identity, they imply

$$\begin{aligned} [[x, F^M], F^N] \partial_{(M} \otimes \partial_{N)} &= 0, \\ [[x, \tilde{F}^M], \tilde{F}^N] \partial_{[M} \otimes \partial_{N]} &= 0 \end{aligned} \tag{3.2}$$

for any element $x \in \mathcal{B}(\mathfrak{g}_{r+1})$. We refer to refs. [2,3] for details concerning *e.g.* the importance of Eqs. (3.1) for the generalised Lie derivative, and the construction of solutions to the section constraint.

The generalised Lie derivative, acting on an element in R_1 , has the form

$$\mathcal{L}_U V^M = U^N \partial_N V^M + Z_{PQ}{}^{MN} \partial_N U^P V^Q, \tag{3.3}$$

where the invariant tensor Z has the universal expression [2,40]

$$\sigma Z = -\eta_{\alpha\beta} t^\alpha \otimes t^\beta + (\lambda, \lambda) - 1 \tag{3.4}$$

(σ is the permutation operator), *i.e.*, $Z_{PQ}{}^{MN} = -\eta_{\alpha\beta} (t^\alpha)_P{}^N (t^\beta)_Q{}^M + ((\lambda, \lambda) - 1) \delta_P^N \delta_Q^M$. With the help of the structure constants of $\mathcal{B}(\mathfrak{g}_{r+1})$ it can now be written [3]

$$\mathcal{L}_U V = [[U, \tilde{F}^N], \partial_N V^\sharp] - [[\partial_N U^\sharp, \tilde{F}^N], V], \tag{3.5}$$

where $U = U^M E_M$, $V = V^M E_M$, with U^M and V^M bosonic. The two terms in this expression corresponds to the first and second terms in Eq. (3.3), respectively, using the fourth and seventh equations in (2.14). It becomes clear that the superalgebra $\mathcal{B}(\mathfrak{g}_r)$ does not provide the structure needed to construct a generalised Lie derivative, but that $\mathcal{B}(\mathfrak{g}_{r+1})$ does. In the following Section we will show that this construction not only is made possible, but that the generalised Lie derivative arises naturally from considering the properties of a derivative.

We introduce the following notation for the antisymmetrisation, which will be the 2-bracket in the L_∞ algebra,

$$2[[U, V]] = \mathcal{L}_U V - \mathcal{L}_V U = [[U, \tilde{F}^N], \partial_N V^\sharp] - [[\partial_N U^\sharp, \tilde{F}^N], V] - (U \leftrightarrow V). \tag{3.6}$$

For the symmetric part we have

$$\begin{aligned} 2\langle U, V \rangle &= \mathcal{L}_U V + \mathcal{L}_V U \\ &= [[U, \tilde{F}^N], \partial_N V^\sharp] - [[\partial_N U^\sharp, \tilde{F}^N], V] \\ &\quad + [[V, \tilde{F}^N], \partial_N U^\sharp] - [[\partial_N V^\sharp, \tilde{F}^N], U] \\ &= [[U, \partial_M V^\sharp], \tilde{F}^M] - [[\partial_M U^\sharp, V], \tilde{F}^M], \end{aligned} \tag{3.7}$$

where we have used the Jacobi identity. If $\tilde{R}_2 = 0$, then

$$[\tilde{E}_M, E_N] = [\tilde{E}_N, E_M] = -[E_M, \tilde{E}_N] \tag{3.8}$$

so that $[\partial_M \tilde{U}, V] = -[\partial_M U, \tilde{V}]$ and $2\langle U, V \rangle = \partial_M [[U, \tilde{V}], \tilde{F}^M]$.

In the cases where $\mathcal{L}_U \mathcal{L}_V - \mathcal{L}_V \mathcal{L}_U = \mathcal{L}_{\llbracket U, V \rrbracket}$ we get

$$\begin{aligned}
 2(\llbracket \llbracket U, V \rrbracket, W \rrbracket) &= \mathcal{L}_{\llbracket U, V \rrbracket} W + \mathcal{L}_W \llbracket U, V \rrbracket \\
 &= 2\mathcal{L}_U \mathcal{L}_V W + \mathcal{L}_W \mathcal{L}_U V = 3\mathcal{L}_U \mathcal{L}_V W \\
 &= 3(2\mathcal{L}_U \mathcal{L}_V W - \mathcal{L}_W \mathcal{L}_U V) \\
 &= 3(\mathcal{L}_{\llbracket U, V \rrbracket} W - \mathcal{L}_W \llbracket U, V \rrbracket) = 6\llbracket \llbracket U, V \rrbracket, W \rrbracket \quad (3.9)
 \end{aligned}$$

antisymmetrised in U, V, W . These expressions, and their generalisations, will return with ghosts as arguments in Section 6. Note however that U and V have bosonic components. They will be replaced by fermionic ghosts, which together with fermionic basis elements build bosonic elements. The bracket will be graded symmetric.

4. Derivatives, Generalised Lie Derivatives and Other Operators

In this Section, we will start to examine operators on elements at height 0, which are functions of coordinates in R_1 . Beginning with a derivative, and attempting to get as close as possible to a derivation property, we are naturally led to the generalised Lie derivative, extended to all positive levels. The generalised Lie derivative is automatically associated with a graded symmetry, as opposed to the graded antisymmetry of the algebra bracket. This will serve as a starting point for the L_∞ brackets. Other operators arise as obstructions to various desirable properties, and will represent contributions from ancillary ghosts. Various identities fulfilled by the operators will be derived; they will all be essential to the formulation of the L_∞ brackets and the proof of their identities.

4.1. The derivative. Define a derivative $d: R_{(p,0)} \rightarrow R_{(p-1,0)}$ ($p > 0$) by

$$dA = \begin{cases} 0, & A \in R_{(1,0)}, \\ [\partial_M A^\sharp, \tilde{F}^M], & A \in R_{(p,0)}, p > 1. \end{cases} \quad (4.1)$$

It fulfils $d^2 = 0$ thanks to the section constraint. At levels $p > 1$ (and height 0),

$$dA_p = \frac{1}{p} [\partial_M A, F^M]. \quad (4.2)$$

This follows from

$$[A_p^\sharp, \tilde{F}^M] = \frac{1}{p} [[A_p, e], \tilde{F}^M] = \frac{1}{p} [A_p, F^M] + \frac{1}{p} [[A_p, \tilde{F}^M], e], \quad (4.3)$$

where $[A_p, \tilde{F}^M] = 0$ for $p > 1$.

Only insisting on having a nilpotent derivative does not determine the relative coefficients depending on the level p in Eq. (4.2). The subsequent considerations will however depend crucially on the coefficient.

4.2. *Generalised Lie derivative from “almost derivation”.* The derivative is not a derivation, but its failure to be one is of a useful form. It consists of two parts, one being connected to the generalised Lie derivative, and the other to the appearance of modules \tilde{R}_p . The almost-derivation property is derived using Eq. (2.22), which allows moving around raising operators at the cost of introducing height 1 elements. Let p_A, p_B be the levels of A, B . One can then use the two alternative forms

$$[A, B]^\sharp = \begin{cases} [A, B^\sharp] + (-1)^{|B|} \frac{p_A}{p_A+p_B} [A^\sharp, B^\sharp]^\flat, \\ (-1)^{|B|} [A^\sharp, B] - (-1)^{|B|} \frac{p_B}{p_A+p_B} [A^\sharp, B^\sharp]^\flat \end{cases} \quad (4.4)$$

to derive

$$\begin{aligned} d[A, B] &= [[A, \partial_M B]^\sharp, \tilde{F}^M] + [[\partial_M A, B]^\sharp, \tilde{F}^M] \\ &= [[A, \partial_M B^\sharp], \tilde{F}^M] + (-1)^{|B|} \frac{p_A}{p_A+p_B} [[A^\sharp, \partial_M B^\sharp]^\flat, \tilde{F}^M] \\ &\quad + (-1)^{|B|} [[\partial_M A^\sharp, B], \tilde{F}^M] - (-1)^{|B|} \frac{p_B}{p_A+p_B} [[\partial_M A^\sharp, B^\sharp]^\flat, \tilde{F}^M] \\ &= [[A, \tilde{F}^M], \partial_M B^\sharp] + [A, [\partial_M B^\sharp, \tilde{F}^M]] \\ &\quad + (-1)^{|B|} [\partial_M A^\sharp, [B, \tilde{F}^M]] + (-1)^{|B|} [[\partial_M A^\sharp, \tilde{F}^M], B] \\ &\quad + (-1)^{|B|} \frac{p_A \partial_M^{(B)} - p_B \partial_M^{(A)}}{p_A+p_B} [[A^\sharp, B^\sharp], \tilde{F}^M]^\flat \\ &= [[A, \tilde{F}^M], \partial_M B^\sharp] + [A, dB] + \delta_{p_B,1} [A, [\partial_M B^\sharp, \tilde{F}^M]] \\ &\quad + (-1)^{|B|} [\partial_M A^\sharp, [B, \tilde{F}^M]] + (-1)^{|B|} [dA, B] + \delta_{p_A,1} (-1)^{|B|} [[\partial_M A^\sharp, \tilde{F}^M], B] \\ &\quad + (-1)^{|B|} \frac{p_A \partial_M^{(B)} - p_B \partial_M^{(A)}}{p_A+p_B} [[A^\sharp, B^\sharp], \tilde{F}^M]^\flat \\ &= [A, dB] + (-1)^{|B|} [dA, B] \\ &\quad + \delta_{p_A,1} \left([[A, \tilde{F}^M], \partial_M B^\sharp] + (-1)^{|B|} [[\partial_M A^\sharp, \tilde{F}^M], B] \right) \\ &\quad - (-1)^{|A||B|} \delta_{p_B,1} \left([[B, \tilde{F}^M], \partial_M A^\sharp] + (-1)^{|A|} [[\partial_M B^\sharp, \tilde{F}^M], A] \right) \\ &\quad + (-1)^{|B|} \frac{p_A \partial_M^{(B)} - p_B \partial_M^{(A)}}{p_A+p_B} [[A^\sharp, B^\sharp], \tilde{F}^M]^\flat \end{aligned} \quad (4.5)$$

where superscript on derivatives indicate on which field they act. We recognise the generalised Lie derivative from Eq. (3.5) in the second and third lines in the last step, and we define, for arbitrary A, B ,

$$\mathcal{L}_A B = \delta_{p_A,1} \left([[A, \tilde{F}^M], \partial_M B^\sharp] + (-1)^{|B|} [[\partial_M A^\sharp, \tilde{F}^M], B] \right). \quad (4.6)$$

The extension is natural: a parameter A with $p_A > 1$ generates a vanishing transformation, while the action on arbitrary elements is the one which follows from demanding a Leibniz rule for the generalised Lie derivative. Note that bosonic components at level 1 implies fermionic elements, hence the signs in Eqs. (3.5) and (4.6) agree. The last term in Eq. (4.5) is present only if $\tilde{R}_{p_A+p_B}$ is non-empty, since $[A^\sharp, B^\sharp]$ is an element at

height 2 with $[A^\sharp, B^\sharp]^\sharp = 0$. We will refer to such terms as ancillary terms, and denote them $-R^b(A, B)$, *i.e.*,

$$R^b(A, B) = -(-1)^{|B|} \frac{P_A \partial_M^{(B)} - P_B \partial_M^{(A)}}{P_A + P_B} [[A^\sharp, B^\sharp], \tilde{F}^M]^b. \tag{4.7}$$

A generic ancillary element will be an element $K^b \in R_p$ at height 0 (or raised to K at height 1) obtained from an element $B_M \in \tilde{R}_{p+1}$ at height 1 as $K^b = [B_M, \tilde{F}^M]$. The extra index on B_M is assumed to be “in section”. See Section 7 for a more complete discussion.

The derivative is thus “almost” a derivation, but the derivation property is broken by two types of terms, the generalised Lie derivative and an ancillary term:

$$d[A, B] - [A, dB] - (-1)^{|B|}[dA, B] = \mathcal{L}_A B - (-1)^{|A||B|} \mathcal{L}_B A - R^b(A, B). \tag{4.8}$$

The relative factor with which the derivative acts on different levels is fixed by the existence of the almost derivation property.

Equation (4.8) states that the symmetry of $\mathcal{L}_A B$ is graded symmetric, modulo terms with “derivatives”, which in the end will be associated with exact terms. This is good, since it means that we, roughly speaking, have gone from the graded antisymmetry of the superalgebra bracket to the desired symmetry of an L_∞ bracket. The graded antisymmetric part of the generalised Lie derivative appearing in Eq. (4.8) represents what, for bosonic parameters U, V , would be the symmetrised part $\mathcal{L}_U V + \mathcal{L}_V U$, and it can be seen as responsible for the violation of the Jacobi identities (antisymmetry and the Leibniz property imply the Jacobi identities [8]). The generalised Lie derivative (at level 1) will be the starting point for the L_∞ 2-bracket in Sections 6 and 8.

We note that $\mathcal{L}_{dA} B = 0$, $\mathcal{L}_{[A, B]} C = 0$, and that \mathcal{L}_A fulfils a Leibniz rule,

$$\mathcal{L}_A [B, C] = (-1)^{|C|} [\mathcal{L}_A B, C] + (-1)^{|A||B|} [B, \mathcal{L}_A C]. \tag{4.9}$$

Consider the expression (4.6) for the generalised Lie derivative. It agrees with Eq. (3.5) when $p_A = p_B = 1$ and $|A| = |B| = 1$. It is straightforward to see that the expression contains a factor $(-1)^{|B|+1}$ compared to the usual expression for the generalised Lie derivative when expressed in terms of components.

In the present paper, we will assume that the generalised Lie derivative, when acting on an element in $\mathcal{B}_+(\mathfrak{g}_r)$, close. This is *not* encoded in the Borchers superalgebra. We will indicate in the Conclusions what we think will be the correct procedure if this is not the case. We thus assume

$$(\mathcal{L}_A \mathcal{L}_B + (-1)^{|A||B|} \mathcal{L}_B \mathcal{L}_A) C = (-1)^{|C|+1} \mathcal{L}_{\frac{1}{2}(\mathcal{L}_A B + (-1)^{|A||B|} \mathcal{L}_B A)} C, \tag{4.10}$$

where the sign comes from the consideration above. When all components are bosonic and level 1, this becomes the usual expression $(\mathcal{L}_A \mathcal{L}_B - \mathcal{L}_B \mathcal{L}_A) C = \mathcal{L}_{\frac{1}{2}(\mathcal{L}_A B - \mathcal{L}_B A)} C$. If we instead consider a ghost C with $|C| = 0$, then

$$\mathcal{L}_C \mathcal{L}_C C = -\frac{1}{2} \mathcal{L}_{\mathcal{L}_C C} C. \tag{4.11}$$

4.3. “Almost covariance” and related operators. The generalised Lie derivative anti-commutes with the derivative, modulo ancillary terms. This can be viewed as covariance of the derivative, modulo ancillary terms. Namely, combining Eq. (4.8) with entries A and dB with the derivative of Eq. (4.8) gives the relation

$$d\mathcal{L}_A B + \mathcal{L}_A dB = (-1)^{|B|}([dA, dB] - d[dA, B]) + (-1)^{|A||B|}d\mathcal{L}_B A + dR^b(A, B) + R^b(A, dB). \tag{4.12}$$

The left hand side can only give a non-vanishing contribution for $p_A = 1$ and $p_B > 1$. But then the non-ancillary part of the right hand side vanishes. Therefore, we can define an ancillary operator $X_A B$ as

$$d\mathcal{L}_A B + \mathcal{L}_A dB = -X_A^b B. \tag{4.13}$$

The explicit form of X_A is

$$X_A^b B = -(d\mathcal{L}_A + \mathcal{L}_A d)B = -\frac{1}{2}\delta_{p_A,1}[[[\partial_M \partial_N A^\sharp, B^\sharp], \tilde{F}^M], \tilde{F}^N]. \tag{4.14}$$

The notation $X_A^b B$ means $(X_A B)^b$. Thus, $X_A B$ is an element in R_{p_B-1} at height 1. It will be natural to extend the action of the derivative and generalised Lie derivative to elements K at height 1 by

$$dK = -(dK^b)^\sharp, \tag{4.15}$$

$$\mathcal{L}_C K = -(\mathcal{L}_C K^b)^\sharp.$$

Then, $db + bd = 0$ and $\mathcal{L}_C b + b\mathcal{L}_C = 0$.

Note that $X_{dA} B = 0$ and $X_{[A,B]} C = 0$, directly inherited from the generalised Lie derivative. In addition, we always have

$$\mathcal{L}_{X_A^b B} C = 0. \tag{4.16}$$

If $\tilde{R}_2 = 0$ this statement is trivial. If \tilde{R}_2 is non-empty (as e.g. for $\mathfrak{g}_r = E_7$), $X_A^b B$ represents a parameter which gives a trivial transformation without being a total derivative, thanks to the section constraint.

4.4. More operator identities. The operator X_A^b obeys the important property

$$dX_A^b B - X_A^b dB = 0. \tag{4.17}$$

It follows from the definition of X_A^b and the nilpotency of d as

$$dX_A^b B - X_A^b dB = -d(d\mathcal{L}_A B + \mathcal{L}_A dB) + (d\mathcal{L}_A + \mathcal{L}_A d)dB = 0. \tag{4.18}$$

It can also be verified by the direct calculation

$$\begin{aligned} dX_A^b B - X_A^b dB &= -\frac{1}{2}\delta_{p_A,1}[[[\partial_P[\partial_M \partial_N A^\sharp, B^\sharp], \tilde{F}^M], \tilde{F}^N]^\sharp, \tilde{F}^P]^\sharp \\ &\quad + \frac{1}{2}\delta_{p_A,1}[[[\partial_M \partial_N A^\sharp, [\partial_P B^\sharp, \tilde{F}^P]^\sharp], \tilde{F}^M], \tilde{F}^N]^\sharp \\ &= \frac{\delta_{p_A,1}}{(p_B - 1)(p_B - 2)} \left([[[\partial_P[\partial_M \partial_N A^\sharp, B^\sharp], \tilde{F}^M], F^N], F^P] \right. \\ &\quad \left. + [[[\partial_M \partial_N A^\sharp, [\partial_P B^\sharp, F^P]], \tilde{F}^M], F^N] \right), \end{aligned} \tag{4.19}$$

where the action of the raising operators have been expanded. In the first term, ∂_P must hit B , the other term vanishes due to the section constraint. In the second term, $[\partial_M \partial_N A^\sharp, [\partial_P B^\sharp, F^P]] = [[\partial_M \partial_N A^\sharp, \partial_P B^\sharp], F^P]$, and the two terms cancel. Note that we are now dealing with identities that hold exactly, not only modulo ancillary terms (they are identities *for* ancillary terms).

An equivalent relation raised to height 1 is

$$(dX_A + X_A d)B = 0. \tag{4.20}$$

A relation for the commutator of X^b with \mathcal{L} is obtained directly from the definition (4.13) of X ,

$$\begin{aligned} & (\mathcal{L}_A X_B^b - X_A^b \mathcal{L}_B + (-1)^{|A||B|} (\mathcal{L}_B X_A^b - X_B^b \mathcal{L}_A)) C \\ &= (-1)^{|C|} X^b_{\frac{1}{2}(\mathcal{L}_A B + (-1)^{|A||B|} \mathcal{L}_B A)} C, \end{aligned} \tag{4.21}$$

or

$$\begin{aligned} & (\mathcal{L}_A X_B + X_A \mathcal{L}_B + (-1)^{|A||B|} (\mathcal{L}_B X_A - X_B \mathcal{L}_A)) C \\ &= (-1)^{|C|+1} X_{\frac{1}{2}(\mathcal{L}_A B + (-1)^{|A||B|} \mathcal{L}_B A)} C. \end{aligned} \tag{4.22}$$

For a ghost C the relation reads

$$\mathcal{L}_C X_C^b C - X_C^b \mathcal{L}_C C = \frac{1}{2} X^b_{\mathcal{L}_C C} C, \tag{4.23}$$

or equivalently,

$$(\mathcal{L}_C X_C + X_C \mathcal{L}_C) C = -\frac{1}{2} X_{\mathcal{L}_C C} C. \tag{4.24}$$

Further useful relations expressing derivation-like properties, derived using the definitions of $X_A B$ and $R(A, B)$, together with Eq. (4.10), are:

$$dR(A, B) - R(A, dB) - (-1)^{|B|} R(dA, B) = X_A B - (-1)^{|A||B|} X_B A \tag{4.25}$$

and

$$\begin{aligned} & \mathcal{L}_A R(B, C) - (-1)^{|A||B|} R(B, \mathcal{L}_A C) - (-1)^{|C|} R(\mathcal{L}_A B, C) \\ &= -X_A [B, C] + (-1)^{|A||B|} [B, X_A C] + (-1)^{|C|} [X_A B, C]. \end{aligned} \tag{4.26}$$

Although $R(A, B)$ is non-vanishing for A and B at all levels (as long as $\widetilde{R}_{p_A+p_B}$ is non-empty), we will sometimes use the notation $R_A B = R(A, B)$. Thanks to the Jacobi identity for the Borchers superalgebra and the Leibniz property of the generalised Lie derivative, $R(A, B)$ satisfies a cyclic identity,

$$\begin{aligned} 0 &= R(A, [B, C]) - R([A, B], C) - (-1)^{|A||B|} R(B, [A, C]) \\ &+ [A, R(B, C)] - [R(A, B), C] - (-1)^{|A||B|} [B, R(A, C)]. \end{aligned} \tag{4.27}$$

5. Batalin–Vilkovisky Ghost Actions and L_∞ Algebras

Let $C \in \mathcal{V}$ be a full set of ghosts, including ghosts for ghosts etc. If the “algebra” of gauge transformations does not contain any field dependence, the Batalin–Vilkovisky (BV) action [44] can be truncated to ghosts and their antifields C^* . We denote this ghost action $S(C, C^*)$, and assume further that it is linear in C^* . The ghost action S can be (formally, if needed) expanded as a power series in C ,

$$S(C, C^*) = \sum_{n=1}^{\infty} \langle C^*, \llbracket C^n \rrbracket \rangle, \tag{5.1}$$

where $\langle \cdot, \cdot \rangle$ is the natural scalar product on the vector space of the ghosts and its dual, and where

$$\llbracket C^n \rrbracket = \underbrace{\llbracket C, C, \dots, C \rrbracket}_n \tag{5.2}$$

is a graded symmetric map from $\otimes^n \mathcal{V}$ to \mathcal{V} . This map is, roughly speaking, the L_∞ n -bracket. The 1-bracket is the BRST operator. The BV variation of C is

$$(S, C) = \sum_{n=1}^{\infty} \llbracket C^n \rrbracket. \tag{5.3}$$

The BV master equation $(S, S) = 0$ becomes, phrased as the nilpotency of the transformation (S, \cdot) , the relation $(S, (S, C)) = 0$, which in the series expansion turns into a set of identities for the brackets [21, 45–47],

$$\sum_{i=0}^{n-1} (i+1) \llbracket C^i, \llbracket C^{n-i} \rrbracket \rrbracket = 0. \tag{5.4}$$

Often, L_∞ algebras are presented with other conventions (see ref. [21] for an overview). This includes a shifted notion of level, equalling ghost number minus 1. Then the n -bracket carries level $n - 2$. In our conventions, all L_∞ brackets carry ghost number -1 , and the superalgebra bracket preserves ghost number. Also, the properties of the brackets under permutation of elements are sometimes presented as governed by “Koszul sign factors”. In our conventions, the L_∞ brackets are simply graded symmetric and the statistics of the ghosts, inherited from the superalgebra, is taking care of all signs automatically.

Since the relation between the BV ghost variation and the L_∞ brackets seems to be established, but not common knowledge among mathematical physicists, we would like to demonstrate the equivalence explicitly. (See also refs. [21, 48].)

In order to go from the compact form (5.4) to a version with n arbitrary elements, let $C = \sum_{k=1}^{\infty} C_k$ and take the part of the identity containing each of the terms in the sum once. We then get

$$\sum_{\substack{i, j \geq 1 \\ i+j=n+1}} j \sum_{\sigma} \llbracket C_{\sigma(i+1)}, \dots, C_{\sigma(n)}, \llbracket C_{\sigma(1)}, \dots, C_{\sigma(i)} \rrbracket \rrbracket = 0, \tag{5.5}$$

where the inner sum is over all permutations σ of $\{1, \dots, n\}$. The standard definition of the L_∞ identities does not involve the sum over all permutations, but over the subset of “unshuffles”, permutations which are ordered inside the two subsets:

$$\begin{aligned} \sigma(1) &< \dots < \sigma(i), \\ \sigma(i+1) &< \dots < \sigma(n). \end{aligned} \tag{5.6}$$

Reexpressing the sum in terms of the sum over unshuffles gives a factor $i!(n-i)!$, which combined with the factor j in Eq. (5.5) gives $i!j!$, Rescaling the brackets according to

$$n![[C_1, \dots, C_n]] = \bar{\ell}(C_1, \dots, C_n) \tag{5.7}$$

turns the identity into

$$\sum_{\substack{i,j \geq 1 \\ i+j=n+1}} \sum'_\sigma \bar{\ell}(C_{\sigma(1)}, \dots, C_{\sigma(j-1)}, \bar{\ell}(C_{\sigma(j)}, \dots, C_{\sigma(n)})) = 0, \tag{5.8}$$

where the primed inner sum denotes summation over unshuffles.

It remains to investigate the sign factors induced by the statistics of the elements in the superalgebra. We therefore introduce a basis $\{c_i\}$ which consists of fermionic elements with odd ghost numbers and bosonic elements with even ghost numbers. Since a ghost is always totally bosonic, this means that ghosts with odd ghost numbers have fermionic components in this basis and ghosts with even ghost numbers have bosonic components. Furthermore, we include the x -dependence of the ghosts in the basis elements c_i (“DeWitt notation”) and thus treat the components as constants that we can move out of the brackets. Then, our identities take the form

$$\sum_{\substack{i,j \geq 1 \\ i+j=n+1}} \sum'_\sigma \varphi_{j-1}(\sigma; c) \bar{\ell}(c_{\sigma(1)}, \dots, c_{\sigma(j-1)}, \bar{\ell}(c_{\sigma(j)}, \dots, c_{\sigma(n)})) = 0, \tag{5.9}$$

where $\varphi_{j-1}(\sigma; c)$ is the sign factor for the permutation σ in the graded symmetrisation of the elements $\{c_1, \dots, c_n, F\}$ to $\{c_{\sigma(1)}, \dots, c_{\sigma(j-1)}, F, c_{\sigma(j)}, \dots, c_{\sigma(n)}\}$. Here, F is a fermionic element used to define the sign factor, which comes from the fact that the brackets are fermionic.

We now turn to the standard definition of L_∞ identities. The Koszul sign factor $\varepsilon(\sigma; x)$ for a permutation σ of n elements $\{x_1, \dots, x_n\}$ is defined inductively by an associative and graded symmetric product

$$x_i \circ x_j = (-1)^{|x_i||x_j|} x_j \circ x_i, \tag{5.10}$$

where $|x_i| = 0$ for “bosonic” x_i and 1 for “fermionic”. Then,

$$x_{\sigma(1)} \circ \dots \circ x_{\sigma(n)} = \varepsilon(\sigma; x) x_1 \circ \dots \circ x_n. \tag{5.11}$$

Multiplying by a factor $(-1)^\sigma$ gives a graded antisymmetric product, which can be seen as a wedge product of super-forms,

$$x_{\sigma(1)} \wedge \dots \wedge x_{\sigma(n)} = (-1)^\sigma \varepsilon(\sigma; x) x_1 \wedge \dots \wedge x_n. \tag{5.12}$$

The standard form of the identities for an L_∞ bracket is

$$\sum_{\substack{i,j \geq 1 \\ i+j=n+1}} (-1)^{i(j-1)} \sum_{\sigma}' (-1)^\sigma \varepsilon(\sigma; x) \ell(\ell(x_{\sigma(1)}, \dots, x_{\sigma(i)}), x_{\sigma(i+1)}, \dots, x_{\sigma(n)}) = 0. \tag{5.13}$$

The two equations (5.9) and (5.13) look almost identical. However, the assignment of “bosonic” and “fermionic” for the c ’s is opposite to the one for the x ’s. On the other hand, the brackets of x ’s are graded antisymmetric, while those of c ’s are graded symmetric. Seen as tensors, such products differ in sign when exchanging bosonic with fermionic indices. There is obviously a difference between a tensor being graded antisymmetric (the “ x picture”) and “graded symmetric with opposite statistics” (the “ c picture”). The two types of tensors are however equivalent as modules (super-plethysms) of a general linear superalgebra. As a simple example, a 2-index tensor which is graded antisymmetric can be represented as a matrix

$$\begin{pmatrix} a & \alpha \\ -\alpha^t & s \end{pmatrix}, \tag{5.14}$$

where a is antisymmetric and s symmetric, while a 2-index tensor which is graded symmetric in the opposite statistics is

$$\begin{pmatrix} a' & \alpha' \\ (\alpha')^t & s' \end{pmatrix}. \tag{5.15}$$

The tensor product $V \otimes V$ of a graded vector space V with itself can always be decomposed as the sum of the two plethysms, graded symmetric and graded antisymmetric, *i.e.*, in the sum of the two super-plethysms. Equivalently, the same decomposition, as modules of the general linear superalgebra $\mathfrak{gl}(V)$, is the sum of the graded antisymmetric and graded symmetric modules with the opposite assignment of statistics. The same is true for higher tensor products $\otimes^n V$.

This means that, as long as the brackets ℓ and $\bar{\ell}$ are taken to be proportional up to signs, the equations (5.9) and (5.13) contain the same number of equations in the same \mathfrak{g} -modules, but not that the signs for the different terms in the identities are equivalent. In order to show this, one needs to introduce an explicit invertible map, a so called suspension, from the “ x picture” to the “ c picture”, *i.e.*, between the two presentations of the plethysms of the general linear superalgebra.

Let us use a basis where all basis elements are labelled by an index $A = (a, \alpha)$, where a and α correspond to fermionic and bosonic basis elements, respectively. We choose an ordering where the a indices are “lower” than the α ones. Any unshuffle then has the index structure $\{a_1 \dots a_k \alpha_1 \dots \alpha_{k'}, a_{k+1} \dots a_\ell \alpha_{k'+1} \dots \alpha_{\ell'}\}$. If the brackets ℓ and $\bar{\ell}$ are expressed in terms of structure constants,

$$\begin{aligned} \ell(x_{A_1}, \dots, x_{A_n}) &= f_{A_1 \dots A_n}^B x_B, \\ \bar{\ell}(c_{A_1}, \dots, c_{A_n}) &= \bar{f}_{A_1 \dots A_n}^B c_B, \end{aligned} \tag{5.16}$$

the respective identities contain terms of the forms

$$\begin{aligned}
 & (-1)^{i(j-1)}(-1)^\sigma \varepsilon(a_1 \dots a_k \alpha_1 \dots \alpha_{k'} a_{k+1} \dots a_\ell \alpha_{k'+1} \dots \alpha_{\ell'}) \\
 & \quad \times f_{a_1 \dots a_k \alpha_1 \dots \alpha_{k'}}^B f_{Ba_{k+1} \dots a_\ell \alpha_{k'+1} \dots \alpha_{\ell'}}^A, \\
 & (-1)^m \varphi_{j-1}(a_{m+1} \dots a_\ell \alpha_{m'+1} \dots \alpha_{\ell'} a_1 \dots a_m \alpha_1 \dots \alpha_{m'}) \\
 & \quad \times \bar{f}_{a_{m+1} \dots a_\ell \alpha_{m'+1} \dots \alpha_{\ell'}}^B \bar{f}_{a_1 \dots a_m \alpha_1 \dots \alpha_{m'}}^A,
 \end{aligned} \tag{5.17}$$

where $k + m = \ell, k' + m' = \ell', k + k' = i, m + m' = j - 1$ (i, j being the same variables as in the sums (5.9) and (5.13)). Now, both expressions need to be arranged to the same index structure, which we choose as $a_1 \dots a_\ell \alpha_1 \dots \alpha_{\ell'}$. This gives a factor $(-1)^{k'm}$ for the f^2 term, and $(-1)^{km}$ for \bar{f}^2 . In order to compare the two brackets, we also need to move the summation index B to the right on f when $B = \beta$ and to the left on \bar{f} when $B = b$. All non-vanishing brackets have a total odd number of “ a indices”, including the upper index, so $B = b$ when k is even, and $B = \beta$ when k is odd. This gives a factor $(-1)^m$ for the f^2 expression when k is odd, and $(-1)^m$ for \bar{f}^2 when k is even.

The task is now to find a relation

$$\bar{f}_{a_1 \dots a_k \alpha_1 \dots \alpha_{k'}}^B = \varrho(k, k') f_{a_1 \dots a_k \alpha_1 \dots \alpha_{k'}}^B \tag{5.18}$$

for some sign $\varrho(k, k')$. The resulting relative sign between the two expressions in Eq. (5.17) must then be the same for all terms in an identity, *i.e.*, it should only depend on $\ell = k + m$ and $\ell' = k' + m'$. Taking the factors above into consideration, this condition reads

$$\begin{aligned}
 k \text{ even: } & (-1)^{(k+k')m'} \varrho(k, k') \varrho(m + 1, m') = \tau(k + m, k' + m'), \\
 k \text{ odd: } & (-1)^{(k+k')m'} \varrho(k, k') \varrho(m, m' + 1) = \tau(k + m, k' + m').
 \end{aligned} \tag{5.19}$$

This is satisfied for

$$\varrho(k, k') = (-1)^{\frac{1}{2}k'(k'-1)}, \tag{5.20}$$

with $\tau(\ell, \ell') = \varrho(\ell, \ell')$. The last relation is natural, considering that the equations in turn belong to the two different presentations of the same super-plethysm. This gives the explicit translation between the two pictures.

All structure constants carry an odd number of a indices (including the upper one). This is a direct consequence of the fact that all brackets are fermionic in the c picture (since the BV antibracket is fermionic). The relation between the structure constants in the two pictures implies, among other things, that

$$\begin{aligned}
 \bar{f}_a^\beta &= f_a^\beta, \\
 \bar{f}_\alpha^b &= f_\alpha^b, \\
 \bar{f}_{a_1 a_2}^b &= f_{a_1 a_2}^b, \\
 \bar{f}_{a\alpha}^\beta &= f_{a\alpha}^\beta, \\
 \bar{f}_{\alpha_1 \alpha_2}^b &= -f_{\alpha_1 \alpha_2}^b.
 \end{aligned} \tag{5.21}$$

The first two of these equations relate the 1-bracket (derivative) in the two pictures, and the remaining three the 2-bracket. Using these relations we can give an explicit example

of how identities in the two pictures are related to each other. Let us write $|c_a| = 1$ and $|c_\alpha| = 0$. We then have

$$\bar{\ell}(c_A, c_B) = (-1)^{|c_A||c_B|} \bar{\ell}(c_B, c_A), \quad \ell(x_A, x_B) = -(-1)^{(|c_A|+1)(|c_B|+1)} \ell(x_B, x_A). \tag{5.22}$$

Furthermore, the relations (5.21) imply that under the inverse of the suspension,

$$\begin{aligned} \bar{\ell}(c_A) &\mapsto \ell(x_A), \\ \bar{\ell}(c_A, c_B) &\mapsto (-1)^{|c_A|+1} \ell(x_A, x_B). \end{aligned} \tag{5.23}$$

In the c picture, we have the identity

$$\bar{\ell}(\bar{\ell}(c_A, c_B)) + (-1)^{|c_A|} \bar{\ell}(c_A, \bar{\ell}(c_B)) + (-1)^{(|c_A|+1)|c_B|} \bar{\ell}(c_B, \bar{\ell}(c_A)) = 0. \tag{5.24}$$

Moving the inner 1-bracket to the left, the left hand side is equal to the expression

$$\bar{\ell}(\bar{\ell}(c_A, c_B)) + (-1)^{|c_A||c_B|} \bar{\ell}(\bar{\ell}(c_B), c_A) + \bar{\ell}(\bar{\ell}(c_A), c_B), \tag{5.25}$$

which, according to (5.23), is mapped to

$$\begin{aligned} &(-1)^{|c_A|+1} \ell(\ell(x_A, x_B)) + (-1)^{(|c_A|+1)|c_B|} \ell(\ell(x_B), x_A) + (-1)^{|c_A|} \ell(\ell(x_A), x_B) \\ &= (-1)^{|c_A|+1} \left(\ell(\ell(x_A, x_B)) + (-1)^{(|c_A|+1)(|c_B|+1)} \ell(\ell(x_B), x_A) - \ell(\ell(x_A), x_B) \right) \\ &= (-1)^{|c_A|+1} \left(\ell(\ell(x_A, x_B)) - \left(\ell(\ell(x_A), x_B) - (-1)^{(|c_A|+1)(|c_B|+1)} \ell(\ell(x_B), x_A) \right) \right). \end{aligned} \tag{5.26}$$

Setting this to zero gives the identity in the x picture corresponding to the identity (5.24) in the c picture.

Note that the issue with the two pictures arises already when constructing a BRST operator in a situation where one has a mixture of bosonic and fermionic constraints. In the rest of the paper, we stay within the c picture, *i.e.*, we work with ghosts with graded symmetry.

6. The L_∞ Structure, Ignoring Ancillary Ghosts

The following calculation will first be performed disregarding ancillary ghosts, *i.e.*, as if all $\tilde{R}_p = 0$. The results will form an essential part of the full picture, but the structure does not provide an L_∞ subalgebra unless all $\tilde{R}_p = 0$.

We use a ghost C which is totally bosonic, *i.e.*, $|C| = 0$, and which is a general element of $\mathcal{B}_+(\mathfrak{g}_r)$, *i.e.*, a height 0 element of $\mathcal{B}_+(\mathfrak{g}_{r+1})$. This gives the correct statistics of the components, namely the same as the basis elements in the superalgebra. All signs are taken care of automatically by the statistics of the ghosts. While the superalgebra bracket is graded antisymmetric, the L_∞ brackets (by which we mean the brackets in the c picture of the previous Section, before the rescaling of Eq. (5.7)) are graded symmetric. The a index of the previous Section labels ghosts with odd ghost number, and the α index those with even ghost number, and include also the coordinate dependence.

6.1. *Some low brackets.* The 1-bracket acting on a ghosts at height 0 is taken as

$$\llbracket C \rrbracket = dC. \quad (6.1)$$

Then the 1-bracket identity $\llbracket \llbracket C \rrbracket \rrbracket = 0$ (the nilpotency of the BRST operator) is satisfied. The 2-bracket on level 1 elements c is

$$\llbracket c, c \rrbracket = \mathcal{L}_c c, \quad (6.2)$$

in order to reproduce the structure of the generalised diffeomorphisms. This already assumes that there are no ancillary transformations, which also would appear on the right hand side of this equation, and have their corresponding ghosts (we will comment on this situation in the Conclusions). It is natural to extend this to arbitrary levels by writing

$$\llbracket C, C \rrbracket = \mathcal{L}_C C. \quad (6.3)$$

Given the relations (5.21) between low brackets in the two pictures in the previous Section, this essentially identifies the 1- and 2-brackets between components with the ones in the traditional L_∞ language (the x picture). Recall, however, that our ghosts C are elements in the superalgebra, formed as sums of components times basis elements, which lends a compactness to the notation, which becomes index-free.

There are potentially two infinities to deal with, one being the level of the ghosts, the other the number of arguments in a bracket. In order to deal with the first one, we are trying to derive a full set of 2-brackets before going to higher brackets. Of course, the existence of higher level ghosts is motivated by the failure of higher identities, so it may seem premature to postulate Eq. (6.3) before we have seen this happen. However, it is essential for us to be able to deal with brackets for arbitrary elements, without splitting them according to level. The identity for the 2-bracket is then satisfied, since

$$\llbracket \llbracket C, C \rrbracket \rrbracket + 2\llbracket C, \llbracket C \rrbracket \rrbracket = d\mathcal{L}_C C + 2 \cdot \frac{1}{2} \mathcal{L}_C dC = 0. \quad (6.4)$$

Notice that this implies that the 2-bracket between ghosts which are both at level 2 or higher vanishes.

There is of course a choice involved every time a new bracket is introduced, and the choices differ by something exact. The choice will then have repercussions for the rest of the structure. The first choice arises when the need for a level 2 ghost C_2 becomes clear (from the 3-bracket identity as a modification of the Jacobi identity), and its 2-bracket with the level 1 ghost is to be determined. Instead of choosing $\llbracket c, C_2 \rrbracket = \frac{1}{2} \mathcal{L}_c C_2$, corresponding to Eq. (6.4), we could have taken $\llbracket c, C_2 \rrbracket = -\frac{1}{2} [c, dC_2]$, since the derivative of the two expressions are the same (modulo ancillary terms) according to Eq. (4.8). The latter is the type of choice made in *e.g.* Ref. [21]. Any linear combination of the two choices with weight 1 is of course also a solution. However, it turns out that other choices than the one made here lead to expressions that do not lend themselves to unified expressions containing C as a generic element in $\mathcal{B}_+(\mathfrak{g}_r)$. Thus, this initial choice and its continuation are of importance.

We now turn to the 3-bracket. The identity is

$$\llbracket \llbracket C, C, C \rrbracket \rrbracket + 2\llbracket C, \llbracket C, C \rrbracket \rrbracket + 3\llbracket C, C, \llbracket C \rrbracket \rrbracket = 0. \quad (6.5)$$

The second term (the Jacobiator) equals $\mathcal{L}_C \llbracket C, C \rrbracket + \mathcal{L}_{\llbracket C, C \rrbracket} C$. Here we must assume the closure of the transformations, acting on something, *i.e.*, the absence of ancillary transformations in the commutator of two level 1 transformations. Then,

$$\mathcal{L}_C \llbracket C, C \rrbracket = \mathcal{L}_C \mathcal{L}_C C = -\frac{1}{2} \mathcal{L}_{\llbracket C, C \rrbracket} C, \tag{6.6}$$

and the second term in Eq. (6.5) can be written expressed in terms of the (graded) antisymmetric part instead of the symmetric one, so that the derivation property may be used:

$$\begin{aligned} 2\llbracket C, \llbracket C, C \rrbracket \rrbracket &= -\frac{1}{3}(\mathcal{L}_C \mathcal{L}_C C - \mathcal{L}_{\mathcal{L}_C C} C) \\ &= -\frac{1}{3}(d[C, \mathcal{L}_C C] - [C, d\mathcal{L}_C C] + [dC, \mathcal{L}_C C]) \\ &= -\frac{1}{3}(d[C, \mathcal{L}_C C] + [C, \mathcal{L}_C dC] + [dC, \mathcal{L}_C C]) \end{aligned} \tag{6.7}$$

(modulo ancillary terms). If one takes

$$\llbracket C, C, C \rrbracket = \frac{1}{3}[C, \mathcal{L}_C C], \tag{6.8}$$

the identity is satisfied, since then

$$\llbracket \llbracket C, C, C \rrbracket \rrbracket = \frac{1}{3}d[C, \mathcal{L}_C C], \tag{6.9}$$

and

$$3\llbracket C, C, \llbracket C \rrbracket \rrbracket = 3 \cdot \frac{1}{3}(\frac{1}{3}[C, \mathcal{L}_C dC] + \frac{1}{3}[dC, \mathcal{L}_C C]). \tag{6.10}$$

Starting from the 4-bracket identity

$$\llbracket \llbracket C, C, C, C \rrbracket \rrbracket + 2\llbracket C, \llbracket C, C, C \rrbracket \rrbracket + 3\llbracket C, C, \llbracket C, C \rrbracket \rrbracket + 4\llbracket C, C, C, \llbracket C \rrbracket \rrbracket = 0, \tag{6.11}$$

a calculation gives at hand that the second and third terms cancel (still modulo ancillary terms). This would allow $\llbracket C, C, C, C \rrbracket = 0$. The calculation goes as follows. We use the brackets and identities above to show

$$\begin{aligned} \llbracket C, \llbracket C, C, C \rrbracket \rrbracket &= \frac{1}{3}\llbracket C, [C, \mathcal{L}_C C] \rrbracket = \frac{1}{6}\mathcal{L}_C [C, \mathcal{L}_C C] \\ &= -\frac{1}{6}[\mathcal{L}_C C, \mathcal{L}_C C] + \frac{1}{6}[C, \mathcal{L}_C \mathcal{L}_C C] \\ &= -\frac{1}{6}[\mathcal{L}_C C, \mathcal{L}_C C] - \frac{1}{12}[C, \mathcal{L}_{\mathcal{L}_C C} C] \end{aligned} \tag{6.12}$$

and

$$\begin{aligned} \llbracket C, C, \llbracket C, C \rrbracket \rrbracket &= \frac{1}{9}([\mathcal{L}_C C, \mathcal{L}_C C] + [C, \mathcal{L}_{\mathcal{L}_C C} C] + [C, \mathcal{L}_C \mathcal{L}_C C]) \\ &= \frac{1}{9}[\mathcal{L}_C C, \mathcal{L}_C C] + \frac{1}{18}[C, \mathcal{L}_{\mathcal{L}_C C} C]. \end{aligned} \tag{6.13}$$

This does not imply that all higher brackets vanish. Especially, the middle term $3\llbracket C, C, \llbracket C, C, C \rrbracket \rrbracket$ in the 5-bracket identity is non-zero, which requires a 5-bracket.

6.2. *Higher brackets.* In order to go further, we need to perform calculations at arbitrary order. There is essentially one possible form for the n -bracket, namely

$$\llbracket C^n \rrbracket = k_n (\text{ad } C)^{n-2} \mathcal{L}_C C. \quad (6.14)$$

It turns out that the constants k_n are given by Bernoulli numbers,

$$k_{n+1} = \frac{2^n B_n^+}{n!}, \quad (6.15)$$

where $B_n^+ = (-1)^n B_n$ (which only changes the sign for $n = 1$, since higher odd Bernoulli numbers are 0).

We will first show that it is consistent to set all $\llbracket C^{2n} \rrbracket = 0$, $n \geq 2$. Then the $2(n+1)$ -identity reduces to

$$0 = 2\llbracket C, \llbracket C^{2n+1} \rrbracket \rrbracket + (2n+1)\llbracket C^{2n}, \llbracket C, C \rrbracket \rrbracket. \quad (6.16)$$

Evaluating the two terms gives

$$\begin{aligned} \llbracket C, \llbracket C^{2n+1} \rrbracket \rrbracket &= \llbracket C, k_{2n+1} (\text{ad } C)^{2n-1} \mathcal{L}_C C \rrbracket \\ &= \frac{1}{2} k_{2n+1} \mathcal{L}_C (\text{ad } C)^{2n-1} \mathcal{L}_C C \\ &= \frac{1}{2} k_{2n+1} \left((\text{ad } C)^{2n-1} \mathcal{L}_C \mathcal{L}_C C - \sum_{i=0}^{2n-2} (\text{ad } C)^i \text{ad } \mathcal{L}_C C (\text{ad } C)^{2n-2-i} \mathcal{L}_C C \right) \\ &= \frac{1}{2} k_{2n+1} \left(-\frac{1}{2} (\text{ad } C)^{2n-1} \mathcal{L}_C \mathcal{L}_C C - \sum_{i=0}^{2n-2} (\text{ad } C)^i \text{ad } \mathcal{L}_C C (\text{ad } C)^{2n-2-i} \mathcal{L}_C C \right), \end{aligned} \quad (6.17)$$

$$\begin{aligned} \llbracket C^{2n}, \llbracket C, C \rrbracket \rrbracket &= \frac{k_{2n+1}}{2n+1} \left((\text{ad } C)^{2n-1} \mathcal{L}_C \mathcal{L}_C C + (\text{ad } C)^{2n-1} \mathcal{L}_C C C \right. \\ &\quad \left. + \sum_{i=0}^{2n-2} (\text{ad } C)^i \text{ad } \mathcal{L}_C C (\text{ad } C)^{2n-2-i} \mathcal{L}_C C \right) \\ &= \frac{k_{2n+1}}{2n+1} \left(\frac{1}{2} (\text{ad } C)^{2n-1} \mathcal{L}_C \mathcal{L}_C C + \sum_{i=0}^{2n-2} (\text{ad } C)^i \text{ad } \mathcal{L}_C C (\text{ad } C)^{2n-2-i} \mathcal{L}_C C \right), \end{aligned} \quad (6.18)$$

which shows that Eq. (6.16) is fulfilled.

We then turn to the general n -identities, $n \geq 2$ (the remaining ones are those with odd n). They are

$$0 = \llbracket \llbracket C^n \rrbracket \rrbracket + \sum_{i=1}^{n-2} (i+1) \llbracket C^i, \llbracket C^{n-i} \rrbracket \rrbracket + n \llbracket C^{n-1}, \llbracket C \rrbracket \rrbracket. \quad (6.19)$$

The first term equals $k_n d(\text{ad } C)^{n-2} \mathcal{L}_C C$. Repeated use of Eq. (4.8) (without the ancillary term) gives

$$\begin{aligned}
 d(\text{ad } C)^{n-2} \mathcal{L}_C C &= - \sum_{i=0}^{n-3} (\text{ad } C)^i \text{ad } dC (\text{ad } C)^{n-i-3} \mathcal{L}_C C \\
 &- \frac{n}{2} (\text{ad } C)^{n-3} \mathcal{L}_{\mathcal{L}_C C} C - \sum_{i=0}^{n-4} (i+1) (\text{ad } C)^i \text{ad } \mathcal{L}_C C (\text{ad } C)^{n-i-4} \mathcal{L}_C C. \quad (6.20)
 \end{aligned}$$

The first sum cancels the last term in Eq. (6.19). We now evaluate the middle terms under the summation sign in Eq. (6.19).

$$\begin{aligned}
 \llbracket C^i, \llbracket C^{n-i} \rrbracket \rrbracket &= \frac{k_{i+1} k_{n-i}}{i+1} \left(-\frac{1}{2} (\text{ad } C)^{n-3} \mathcal{L}_{\mathcal{L}_C C} C \right. \\
 &+ \sum_{j=0}^{i-2} (\text{ad } C)^j \text{ad} \left((\text{ad } C)^{n-i-2} \mathcal{L}_C C \right) (\text{ad } C)^{i-j-2} \mathcal{L}_C C \\
 &\left. - \sum_{j=0}^{n-i-3} (\text{ad } C)^{i+j-1} \text{ad } \mathcal{L}_C C (\text{ad } C)^{n-i-j-3} \mathcal{L}_C C \right). \quad (6.21)
 \end{aligned}$$

Here we have ignored the insertion of the 2-bracket in the argument of the generalised Lie derivative in the $(n-1)$ -bracket (which changes the sign of the term with $\mathcal{L}_{\mathcal{L}_C C} C$), since this already has been taken care of in Eqs. (6.17) and (6.18). It does not appear in the identity for odd n .

Let $n = 2m + 1$ and $i = 2j$. There is a single term containing $\mathcal{L}_{\mathcal{L}_C C} C$, namely

$$- \frac{k_{2j+1} k_{2(m-j)+1}}{2(2j+1)} (\text{ad } C)^{2m-2} \mathcal{L}_{\mathcal{L}_C C} C. \quad (6.22)$$

The total coefficient of this term in Eq. (6.19) demands that

$$k_{2n+1} = -\frac{1}{2n+1} \sum_{j=1}^{n-1} k_{2j+1} k_{2(n-j)+1}. \quad (6.23)$$

It is straightforward to show that the Bernoulli numbers satisfy the identity

$$\sum_{j=1}^{m-1} \frac{B_{2j} B_{2(m-j)}}{(2j)!(2(m-j))!} = -(2m+1) \frac{B_{2m}}{(2m)!}. \quad (6.24)$$

It follows from the differential equation $\frac{d}{dt} [t(f - \frac{t^2}{12})] + f^2 = 0$, satisfied by

$$f(t) = \frac{t}{e^t - 1} + \frac{t}{2} - 1, \quad \text{where} \quad \frac{t}{e^t - 1} = \sum_{n=0}^{\infty} \frac{B_n}{n!} t^n. \quad (6.25)$$

The $(2m+1)$ -identity (6.19) then is satisfied with the coefficients given by Eq. (6.15). The initial value $k_3 = \frac{1}{3}$ fixes the coefficients to the values in Eq. (6.15). Bernoulli numbers as coefficients of L_∞ brackets have been encountered earlier [49,50].

In order to show that the identities are satisfied at all levels, we use the method devised by Getzler [50] (although our expressions seem to be quite different from the ones in that paper). All expressions remaining after using the derivation property and identifying the coefficients using the $\mathcal{L}\mathcal{L}_C C$ terms are of the form

$$Z_{n,j,k} = (\text{ad } C)^{n-4-j-k} [(\text{ad } C)^j \mathcal{L}_C C, (\text{ad } C)^k \mathcal{L}_C C]. \tag{6.26}$$

There are however many dependencies among these expressions. First one observes that, since $\mathcal{L}_C C$ is fermionic, $Z_{n,j,k} = Z_{n,k,j}$. Furthermore, the Jacobi identity immediately gives

$$Z_{n,j,k} = Z_{n,j+1,k} + Z_{n,j,k+1} \tag{6.27}$$

for $j + k < n - 4$. If one associates the term $Z_{n,j,k}$ with the monomial $s^j t^k$, the Jacobi identity implies $s^j t^k \approx s^{j+1} t^k + s^j t^{k+1}$, i.e., $(s + t - 1)s^j t^k \approx 0$. We can then replace s by $1 - t$, so that $s^j t^k$ becomes $(1 - t)^j t^k$. The symmetry property is taken care of by symmetrisation, so that the final expression corresponding to $Z_{n,j,k}$ is

$$\frac{1}{2}((1 - t)^j t^k + t^j (1 - t)^k). \tag{6.28}$$

All expressions are reduced to polynomials of degree up to $n - 4$ in one variable, symmetric under $t \leftrightarrow 1 - t$. An independent basis consists of even powers of $t - \frac{1}{2}$. In addition to the equations with $\mathcal{L}\mathcal{L}_C C$ that we have already checked, there are $m - 1$ independent equations from the terms with $(\mathcal{L}_C C)^2$ in the $(2m + 1)$ -identity, involving k_{2m+1} and products of lower odd k 's.

We will now show that all identities are satisfied by translating them into polynomials with Getzler's method, using the generating function for the Bernoulli numbers.

Take the last sum in Eq. (6.20). It represents the contribution from the first and last terms in the identity. It translates into the polynomial

$$-k_n \sum_{i=0}^{n-4} (i + 1)t^{n-i-4} = -k_n \frac{n - 3 - (n - 2)t + t^{n-2}}{(1 - t)^2}. \tag{6.29}$$

The terms from the middle terms in the identity (Eq. (6.21)) translate into

$$\begin{aligned} & \sum_{i=1}^{n-2} k_{i+1} k_{n-i} \left(\sum_{j=0}^{i-2} s^{n-i-2} t^{i-j-2} - \sum_{j=0}^{n-i-3} t^{n-i-j-3} \right) \\ &= \sum_{i=1}^{n-2} k_{i+1} k_{n-i} \left(s^{n-i-2} \frac{1 - t^{i-1}}{1 - t} - \frac{1 - t^{n-i-2}}{1 - t} \right). \end{aligned} \tag{6.30}$$

Let $f(x)$ be the generating function for the coefficients k_n , i.e.,

$$\begin{aligned} f(x) &= \sum_{n=2}^{\infty} k_n x^n = \sum_{n=1}^{\infty} \frac{2^n B_n^+}{n!} x^{n+1} = \frac{2x^2}{1 - e^{-2x}} - x \\ &= x^2 + \frac{1}{3}x^3 - \frac{1}{45}x^5 + \frac{2}{945}x^7 - \frac{1}{4725}x^9 + \frac{2}{93555}x^{11} - \frac{1382}{638512875}x^{13} + \dots \end{aligned} \tag{6.31}$$

We now multiply the contributions from Eqs. (6.29) and (6.30), symmetrised in s and t , by x^n and sum over n , identifying the function f when possibility is given. This gives

$$\begin{aligned} & \frac{1}{2(1-t)^2} \left(-(1-t)x f'(x) + (3-2t)f(x) - \frac{f(tx)}{t^2} \right) \\ & + \frac{1}{2(1-t)x} \left(-f(x)^2 + \frac{f(x)f(sx)}{s^2} + \frac{f(x)f(tx)}{t^2} - \frac{f(sx)f(tx)}{s^2 t^2} \right) + (s \leftrightarrow t). \end{aligned} \tag{6.32}$$

When the specific function f is used, this becomes, after some manipulation,

$$\begin{aligned} \phi(s, t, x) = & \frac{(s+t-1)x}{2st} - \frac{(s+t-1)(2-s)x^2}{2t(1-s)^2} \frac{\sinh((1-s)x)}{\sinh x \sinh(sx)} \\ & - \frac{(s+t-1)(2-t)x^2}{2s(1-t)^2} \frac{\sinh((1-t)x)}{\sinh x \sinh(tx)} \\ & + \frac{(s+t-2)x^3}{2(1-s)(1-t)} \frac{1}{\sinh^2 x} \left(1 - \frac{\sinh((1-s)x) \sinh((1-t)x)}{\sinh(sx) \sinh(tx)} \right). \end{aligned} \tag{6.33}$$

This expression clearly vanishes when $s+t-1=0$, which proves that the identities for the brackets hold to all orders.

The function $\phi(s, t, x) = \sum_{n=2}^\infty \phi_n(s, t)$, with the coefficient functions $\phi_n(s, t)$ given by the sum of Eqs. (6.29) and (6.30), symmetrised in s and t , will appear again in many of the calculations for the full identities in Section 8.

The complete variation $(S, C) = \sum_{n=1}^\infty \llbracket C^n \rrbracket$ can formally be written as

$$(S, C) = dC + g(\text{ad } C) \mathcal{L}_C C, \tag{6.34}$$

where g is the function

$$g(x) = \frac{1}{x^2} f(x) = \frac{2}{1-e^{-2x}} - \frac{1}{x}. \tag{6.35}$$

Then $(S, (S, C)) = 0$. This concludes the analysis in the absence of ancillary terms.

7. Ancillary Ghosts

We have already encountered ‘‘ancillary terms’’, whose appearance in various identities for the operators, such as the deviation of d from being a derivation and the deviation of d from being covariant, rely on the existence of modules \tilde{R}_p . Note that the Borchers superalgebra always has $\tilde{R}_1 = \emptyset$, i.e., $R_{(1,1)} = R_1$; this is what prevents us from treating situations where already the gauge ‘‘algebra’’ of generalised Lie derivatives contains ancillary transformations. The ancillary terms at level p appear as $[B_M^\sharp, \tilde{F}^M]^\flat = [B_M, \tilde{F}^M]$, where B_M is an element in \tilde{R}_{p+1} at height 1 (i.e., $B_M^b = 0$). B_M carries an extra \tilde{R}_1 index, which is ‘‘in section’’, meaning that the relations (3.1) are fulfilled also when one or two ∂_M ’s are replaced by a B_M .

The appearance of ancillary terms necessitates the introduction of ancillary ghosts. We will take them as elements $K_p \in R_p$ at height 1 constructed as above. The idea is then to extend the 1-bracket to include the operator \flat , which makes it possible to cancel

Table 2. The typical structure of the action of the 1-bracket between the ghost modules, with ancillary ghosts appearing from level $p_0 \geq 1$

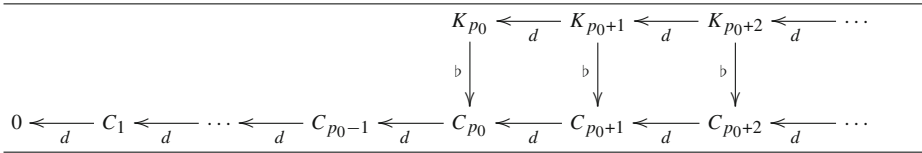

ancillary terms in identities (ignored in the previous Section) by a “derivative” \flat of other terms at height 1.

The derivative d and the generalised Lie derivative \mathcal{L}_C are extended to level 1 as in Section 4.3. This implies that \flat anticommutes with d and with \mathcal{L}_C . Since $d^2 = 0$ and $d\flat + \flat d = 0$ on elements in R_p at height 0 and 1, it can be used in the construction of a 1-bracket, including the ancillary ghosts. The generic structure is shown in Table 2.

Ancillary elements form an ideal \mathcal{A} of $\mathcal{B}_+(\mathfrak{g}_r)$. Let $K^\flat = [B_M, \tilde{F}^M]$ as above, and let $A \in \mathcal{B}_+(\mathfrak{g}_r)$. Then,

$$[A, K^\flat] = [[A, B_M], \tilde{F}^M] + (-1)^{|A||B|} [B_M, [A, \tilde{F}^M]]. \tag{7.1}$$

The first term is ancillary, since the height 1 element $[A, B_M]$ is an element in $\tilde{R}_{p_A+p_B}$, thanks to $[A, \tilde{B}_M]^\flat = 0$, and the section property of the M index remains. The second term has $[A, \tilde{F}^M] \neq 0$ only for $p_A = 1$, but vanishes thanks to $[B_M, f] = 0$. This shows that $[\mathcal{B}_+(\mathfrak{g}_r), \mathcal{A}] \subset \mathcal{A}$. An explicit example of this ideal, for the E_5 exceptional field theory in the M-theory section, is given in Section 9, Table 7.

Let us consider the action of d on ancillary ghosts K at height 1. Let $B_M \in \tilde{R}_{p+1}$ with height 1, and let $K^\flat = [B_M^\sharp, \tilde{F}^M]^\flat \in R_p$ at height 0. We will for the moment assume that

$$[B_M^\sharp, F^M] = 0. \tag{7.2}$$

This is a purely algebraic condition stating that R_p but not \tilde{R}_p is present in the tensor product $\tilde{R}_{p+1} \otimes \bar{R}_1$ in B_M . Then, $K = [B_M^\sharp, \tilde{F}^M]$. Acting with the derivative gives

$$dK = \frac{1}{p-1} [[\partial_N B_M^\sharp, \tilde{F}^M], F^N] = \frac{1}{p-1} [[\partial_N B_M^\sharp, F^N], \tilde{F}^M] = [B_M'^\sharp, \tilde{F}^M], \tag{7.3}$$

where $B_M'^\sharp = \frac{1}{p-1} [\partial_N B_M^\sharp, F^N]$. The derivative preserves the structure, thanks to the section constraint. Also, the condition (7.2) for B' , $[B_M'^\sharp, F^M] = 0$, is automatically satisfied.

The appearance of modules \tilde{R}_p can be interpreted in several ways. One is as a violation of covariance of the exterior derivative, as above. Another is as a signal that Poincaré’s lemma does not hold. In this sense, ancillary modules encode the presence of “local cohomology”, *i.e.*, cohomology present in an open set. It will be necessary to introduce ghosts removing this cohomology.

Let the lowest level p for which \tilde{R}_{p+1} is non-empty be p_0 . Then it follows that an ancillary element K_{p_0} at level p_0 will be closed, $dK_{p_0} = 0$, and consequently $dK_{p_0}^\flat = 0$. However, K_{p_0} does not need to be a total derivative, since B_M does not need to equal $\partial_M \Lambda$. Indeed, our ancillary terms are generically not total derivatives. An ancillary element at level p_0 represents a local cohomology, a violation of Poincaré’s lemma.

The algebraic condition (7.2) was used to show that the ancillary property is preserved under the derivative. Consider the expression $X_A B$ from Eq. (4.14). Raised to height 1 it gives an expression

$$K = [[\beta_{MN}, F^N], \tilde{F}^M] = [B_M^\sharp, \tilde{F}^M] \tag{7.4}$$

with $B_M^\sharp = [\beta_{MN}, F^N]$, where β_{MN} is symmetric and where both its indices are in section. Then, $[B_M^\sharp, F^M] = 0$, and the condition is satisfied. The same statement can not be made directly for any term $R(A, B)$, since it contains only one derivative. One can however rely the identities (4.25) and (4.26), which immediately show (in the latter case also using the property that ancillary expressions form an ideal) that the derivatives and generalised Lie derivatives of an ancillary expression (expressed as $R^b(A, B)$) is ancillary. This is what is needed to consistently construct the brackets in the following Section.

The section property of B_M implies that $\mathcal{L}_{K^b} A = 0$ when K^b is an ancillary expression (see Eq. (4.16)). This identity is also used in the calculations for the identities of the brackets.

8. The Full L_∞ Structure

We will now display the full L_∞ structure, including ancillary ghosts. The calculations for the L_∞ brackets performed in Section 6 will be revised in order to include ancillary terms.

8.1. *Some low brackets.* The 1-bracket, which now acts on the ghosts C at height 0, and also on ancillary ghosts K at height 1, is $d + b$:

$$[[C + K]] = dC + K^b + dK. \tag{8.1}$$

Since $d^2 = b^2 = db + bd = 0$, the identity $[[[C + K]]] = 0$ is satisfied. The ancillary ghost at lowest level is automatically annihilated by d .

The 2-bracket identity was based on “ $d\mathcal{L}_C C + \mathcal{L}_C dC = 0$ ”, which only holds modulo ancillary terms. We need to modify the 2-bracket to

$$\begin{aligned} [[C, C]] &= \mathcal{L}_C C + X_C C, \\ [[C, K]] &= \frac{1}{2} \mathcal{L}_C K, \\ [[K, K]] &= 0. \end{aligned} \tag{8.2}$$

Then,

$$\begin{aligned} &[[[C, C]]] + 2[[C, [[C]]] \\ &= [[\mathcal{L}_C C + X_C C]] + 2[[C, dC]] \\ &= d\mathcal{L}_C C + X_C^b C + dX_C C + \mathcal{L}_C dC + X_C dC = 0 \end{aligned} \tag{8.3}$$

thanks to Eqs. (4.13) and (4.20), and

$$\begin{aligned} &[[[C, K]]] + 2 \cdot \frac{1}{2} [[C, [[K]]] + 2 \cdot \frac{1}{2} [[K, [[C]]] \\ &= \frac{1}{2} (d\mathcal{L}_C K + (\mathcal{L}_C K)^b + \mathcal{L}_C dK + \mathcal{L}_C K^b + X_C K^b) = 0. \end{aligned} \tag{8.4}$$

The terms at height 1 cancel using $X_C K^b = X_C^b K$, where the sign follows from b passing both a d and an \mathcal{L}_C . Here, we have of course used $\mathcal{L}_{K^b} = 0$. Note that the height 0 identity involving one K is trivial, while the identity at height 1 identity with one K is equivalent to the height 0 identity with no K 's. These are both general features, recurring in all bracket identities. In addition $\llbracket K, K^b \rrbracket = \frac{1}{2} \mathcal{L}_{K^b} K = 0$, implying that the bracket with two K 's consistently can be set to 0.

Consider the middle term in the 3-bracket identity. Including ancillary terms, we have

$$\begin{aligned} 2\llbracket C, \llbracket C, C \rrbracket \rrbracket &= 2\llbracket C, \mathcal{L}_C C + X_C C \rrbracket \\ &= \mathcal{L}_C \mathcal{L}_C C + X_C \mathcal{L}_C C + \mathcal{L}_{\mathcal{L}_C C} C + X_{\mathcal{L}_C C} C + \mathcal{L}_C X_C C \\ &= \frac{1}{2}(\mathcal{L}_{\mathcal{L}_C C} C + X_{\mathcal{L}_C C} C). \end{aligned} \quad (8.5)$$

We know that $\llbracket C, C, C \rrbracket$ contains the non-ancillary term $\frac{1}{3}\llbracket C, \mathcal{L}_C C \rrbracket$. Calculating the contribution from this term to $\llbracket \llbracket C, C, C \rrbracket \rrbracket + 3\llbracket C, C, \llbracket C \rrbracket \rrbracket$ gives

$$\begin{aligned} &\frac{1}{3}d[C, \mathcal{L}_C C] + [C, \mathcal{L}_C dC] + [dC, \mathcal{L}_C C] \\ &= \frac{1}{3}(-\frac{3}{2}\mathcal{L}_{\mathcal{L}_C C} - [C, X_C C]^b - R^b(C, \mathcal{L}_C C)). \end{aligned} \quad (8.6)$$

There is still no sign of something cancelling the second term in Eq. (8.5), but the presence of lowered ancillary terms implies that it is necessary to include the ancillary terms $\frac{1}{3}(\llbracket C, X_C C \rrbracket + R(C, \mathcal{L}_C C))$ in the 3-bracket. The term in $\llbracket \llbracket C, C, C \rrbracket \rrbracket$ from the b part of the 1-bracket will then cancel these. We still need to check the terms at height 1. The height 1 contribution to $\llbracket \llbracket C, C, C \rrbracket \rrbracket + 3\llbracket C, C, \llbracket C \rrbracket \rrbracket$ from $\frac{1}{3}\llbracket C, X_C C \rrbracket$ is

$$\frac{1}{3}(d[C, X_C C] + [C, X_C dC] + [dC, X_C C]) = \frac{1}{3}(\mathcal{L}_C X_C C + R(C, X_C^b C)), \quad (8.7)$$

and from $\frac{1}{3}R(C, \mathcal{L}_C C)$, using Eq. (4.25):

$$\begin{aligned} &\frac{1}{3}(dR(C, \mathcal{L}_C C) + R(C, \mathcal{L}_C dC) + R(dC, \mathcal{L}_C C)) \\ &= \frac{1}{3}(X_C \mathcal{L}_C C - X_{\mathcal{L}_C C} C - R(C, X_C^b C)). \end{aligned} \quad (8.8)$$

The complete height 1 terms in the 3-bracket identity become

$$\left(\frac{1}{2} - \frac{1}{3}\right)X_{\mathcal{L}_C C} C + \frac{1}{3}(\mathcal{L}_C X_C + X_C \mathcal{L}_C)C = 0. \quad (8.9)$$

Checking the 3-bracket identity with two C 's and one K becomes equivalent to the height 0 identity for the bracket with three C 's when

$$\llbracket C, C, K \rrbracket = \frac{1}{9}(\llbracket C, \mathcal{L}_C K \rrbracket + \llbracket K, \mathcal{L}_C C \rrbracket). \quad (8.10)$$

There is also a height 0 part of the CKK identity, which is trivial since b generates no ancillary terms. Again, there is no need for a bracket with CKK , since

$$\llbracket C, K, K^b \rrbracket = \frac{1}{18}(\llbracket K^b, \mathcal{L}_C K \rrbracket + \llbracket K, \mathcal{L}_C K^b \rrbracket) = 0. \quad (8.11)$$

These properties will be reflected at all orders, and we do not necessarily mention them every time.

The 4-bracket identity with four C 's reads

$$\llbracket \llbracket C, C, C, C \rrbracket \rrbracket + 2\llbracket C, \llbracket C, C, C \rrbracket \rrbracket + 3\llbracket C, C, \llbracket C, C \rrbracket \rrbracket + 4\llbracket C, C, C, \llbracket C \rrbracket \rrbracket = 0. \quad (8.12)$$

We will now show that the vanishing of the 4-bracket persists when ancillary terms are taken into account. The height 1 terms in $2\llbracket C, \llbracket C, C, C \rrbracket \rrbracket$ are

$$\frac{1}{3}(X_C[C, \mathcal{L}_C] + \mathcal{L}_C[C, X_C C] + \mathcal{L}_C R(C, \mathcal{L}_C C)), \tag{8.13}$$

and those in $3\llbracket C, C, \llbracket C, C \rrbracket \rrbracket$ become

$$\begin{aligned} &\frac{1}{3}([C, X_C \mathcal{L}_C C] + [C, \mathcal{L}_C X_C C] + [C, X_{\mathcal{L}_C C} C] + 2[\mathcal{L}_C C, X_C C] \\ &\quad + \frac{1}{2}R(C, \mathcal{L}_{\mathcal{L}_C C} C) + R(\mathcal{L}_C C, \mathcal{L}_C C)). \end{aligned} \tag{8.14}$$

The terms cancel, using Eqs. (4.26) and (4.24).

8.2. Higher brackets. The structure encountered so far can be extended to arbitrarily high brackets. Knowing the height 0 part of $\llbracket C^n \rrbracket = k_n(\text{ad } C)^{n-2} \mathcal{L}_C C$ enables us to deduce the ancillary part. Namely, keeping ancillary terms when applying Eq. (4.8) sequentially, calculating the first and last terms in the n -bracket identity gives, apart from the second row of Eq. (6.20),

$$d(\text{ad } C)^{n-2} \mathcal{L}_C C = \dots - \left((\text{ad } C)^{n-2} X_C C + \sum_{i=0}^{n-3} (\text{ad } C)^i R_C(\text{ad } C)^{n-i-3} \mathcal{L}_C C \right)^b. \tag{8.15}$$

This forces the n -bracket to take the form

$$\llbracket C^n \rrbracket = k_n \left((\text{ad } C)^{n-2} (\mathcal{L}_C C + X_C C) + \sum_{i=0}^{n-3} (\text{ad } C)^i R_C(\text{ad } C)^{n-i-3} \mathcal{L}_C C \right). \tag{8.16}$$

It is then reasonable to assume that $\llbracket C^{n-1}, K \rrbracket$ is obtained from the symmetrisation of the height 0 part of $\llbracket C^n \rrbracket$, *i.e.*,

$$\llbracket C^{n-1}, K \rrbracket = \frac{k_n}{n} \left((\text{ad } C)^{n-2} \mathcal{L}_C K + \sum_{i=0}^{n-3} (\text{ad } C)^i \text{ad } K (\text{ad } C)^{n-i-3} \mathcal{L}_C C \right), \tag{8.17}$$

and that brackets with more than one K vanish.

We will show that the set of non-vanishing brackets above is correct and complete. The height 0 identity with only C 's is already satisfied, thanks to the contribution from b in $\llbracket \llbracket C^n \rrbracket \rrbracket$. The height 1 identity with one K contains the same calculation. The height 0 identity with one K is trivial, and just follows from moving b 's in and out of commutators and through derivatives and generalised Lie derivatives. The vanishing of the brackets with more than one K is consistent with the vanishing of $\llbracket C^{n-2}, K^b, K \rrbracket$. Lowering this bracket gives $\llbracket C^{n-2}, K^b, K^b \rrbracket$ which vanishes by statistics, since K^b is fermionic.

The only remaining non-trivial check is the height 1 part of the identity with only C 's. This is a lengthy calculation that relies on all identities exposed in Section 4. We will go through the details by collecting the different types of terms generated, one by one.

A first result of the calculation is that all terms containing more than one ancillary expression X or R cancel. This important consistency condition relies on the precise combination of terms in the n -bracket, but not on the relation between the coefficients k_n . It could have been used as an alternative means to obtain possible brackets.

We then focus on the terms containing X . In addition to its appearance in the brackets, X arises when a derivative or a generalised Lie derivative is taken through an R , according to Eqs. (4.25) and (4.26). It turns out that all terms where X_C appears in an “inner” position in terms of the type $(\text{ad } C)^i X_C (\text{ad } C)^{n-i-3} \mathcal{L}_C C$, with $n - i > 3$, cancel. This again does not depend on the coefficients k_n . Collecting terms $(\text{ad } C)^{n-3} \mathcal{L}_C X_C C$ and $(\text{ad } C)^{n-3} X_C \mathcal{L}_C C$, the part $\llbracket [C^n] \rrbracket + n \llbracket [C^{n-1}, [C]] \rrbracket$ gives a contribution

$$k_n(n - 2)(\text{ad } C)^{n-3} \mathcal{L}_C X_C C \tag{8.18}$$

from the X term in the bracket, and

$$k_n((n - 2)(\text{ad } C)^{n-3} X_C \mathcal{L}_C C - (\text{ad } C)^{n-3} X \mathcal{L}_C C) \tag{8.19}$$

from the R term, together giving

$$-\frac{n}{2} k_n (\text{ad } C)^{n-3} X \mathcal{L}_C C. \tag{8.20}$$

A middle term in the identity, $\llbracket [C^i, [C^{n-i}]] \rrbracket$ contains

$$-\frac{1}{2} k_{i+1} k_{n-i} (\text{ad } C)^{n-3} X \mathcal{L}_C C. \tag{8.21}$$

The total contribution cancels, thanks to the relation (6.23) between the coefficients.

The remaining terms with X are of the types $(\text{ad } C)^j \text{ad } \mathcal{L}_C C (\text{ad } C)^{n-4-j} X_C C$ and $(\text{ad } C)^j \text{ad } X_C C (\text{ad } C)^{n-4-j} \mathcal{L}_C C$ and similar. The first and last term in the identity gives a contribution

$$-k_n \sum_{j=0}^{n-4} (j + 1) (\text{ad } C)^j \text{ad } \mathcal{L}_C C (\text{ad } C)^{n-4-j} X_C C \tag{8.22}$$

from the X term in the n -bracket, and

$$-k_n \sum_{j=0}^{n-4} (j + 1) (\text{ad } C)^j \text{ad } X_C C (\text{ad } C)^{n-4-j} \mathcal{L}_C C \tag{8.23}$$

from the R term. A middle term $\llbracket [C^i, [C^{n-i}]] \rrbracket$ gives

$$\begin{aligned} & k_{i+1} k_{n-i} \left(- \sum_{j=0}^{n-i-3} (\text{ad } C)^{i+j-1} \text{ad } \mathcal{L}_C C (\text{ad } C)^{n-i-j-3} X_C C \right. \\ & - \sum_{j=0}^{n-i-3} (\text{ad } C)^{i+j-1} \text{ad } X_C C (\text{ad } C)^{n-i-j-3} \mathcal{L}_C C \\ & + \sum_{j=0}^{i-2} (\text{ad } C)^j \text{ad } ((\text{ad } C)^{n-i-2} \mathcal{L}_C C) (\text{ad } C)^{i-j-2} X_C C \\ & \left. + \sum_{j=0}^{i-2} (\text{ad } C)^j \text{ad } ((\text{ad } C)^{n-i-2} X_C C) (\text{ad } C)^{i-j-2} \mathcal{L}_C C \right). \tag{8.24} \end{aligned}$$

Note the symmetry between X_C and \mathcal{L}_C in all contributions. We can now represent a term $(\text{ad } C)^{n-4-j-k}[(\text{ad } C)^j \mathcal{L}_C C, (\text{ad } C)^k X_C C]$ by a monomial $s^j t^k$, exactly as in Section 6.2. Since we have the symmetry under $s \leftrightarrow t$, the same rules apply as in that calculation. Indeed, precisely the same polynomials are generated as in Eqs. (6.29) and (6.30). The terms cancel.

Finally, there are terms of various structure with one R and two \mathcal{L} 's. One such structure is $(\text{ad } C)^j R_C (\text{ad } C)^{n-j-4} \mathcal{L} \mathcal{L}_C C$. For each value of j , the total coefficient of the term cancels thanks to $n k_n + \sum_i k_{i+1} k_{n-i} = 0$. Of the remaining terms, many have C as one of the two arguments of R , but some do not. In order to deal with the latter, one needs the cyclic identity (4.27). Let

$$F_j = (\text{ad } C)^j \mathcal{L}_C C \quad \text{and} \quad S_{n,j,k} = (\text{ad } C)^{n-j-k-4} R(F_j, F_k). \tag{8.25}$$

Taking the arguments in the cyclic identity as C , F_j and F_k turns it into

$$S_{n,j,k} - S_{n,j+1,k} - S_{n,j,k+1} = -(\text{ad } C)^{n-j-k-5} (R_C[F_j, F_k] - 2[F_j, R_C F_k]). \tag{8.26}$$

We need to verify that terms containing $S_{n,j,k}$, *i.e.*, not having C as one of the arguments of R , combine into the first three terms of this equations, and thus can be turned into expressions with R_C . Note that this relation is analogous to Eq. (4.27) for $Z_{n,j,k}$ in Section 6.2, but with a remainder term. We now collect such terms. They are

$$-k_n \sum_{j=0}^{n-4} (n-3-j) S_{n,j,0} + \sum_{i=2}^{n-2} k_{i+1} k_{n-i} \left(\sum_{j=0}^{i-2} S_{n,j,n-i-2} - \sum_{j=0}^{n-i-3} S_{n,j,0} \right). \tag{8.27}$$

This is the combination encountered earlier (Eqs. (6.29) and (6.30)), which means that these terms can be converted to terms with R_C . However, since the “ $s+t-1 \approx 0$ ” relation in the form (8.26) now holds only modulo R_C terms, we need to add the corresponding R_C terms to the ones already present.

Let us now proceed to the last remaining terms. They are of two types:

$$\begin{aligned} U_{n,r,j,k} &= (\text{ad } C)^r R_C (\text{ad } C)^{n-r-j-k-5} [(\text{ad } C)^j \mathcal{L}_C C, (\text{ad } C)^k \mathcal{L}_C C], \\ V_{n,r,j,k} &= (\text{ad } C)^{n-r-j-k-5} [(\text{ad } C)^j \mathcal{L}_C C, (\text{ad } C)^k R_C (\text{ad } C)^r \mathcal{L}_C C]. \end{aligned} \tag{8.28}$$

If the j and k indices in both expressions are translated into monomials $s^j t^k$ as before, both expressions should be calculated modulo $s+t-1 \approx 0$ as before. In U , symmetry under $s \leftrightarrow t$ can be used, but not in V . Both types of terms need to cancel for all values of r , since there is no identity that allows us to take $\text{ad } C$ past R_C .

The terms of type $U_{n,r,j,k}$ obtained directly from $[[[C^n]]] + n[[C^{n-1}], [C]]$ are

$$-k_n \sum_{r=0}^{n-5} \sum_{k=0}^{n-r-5} (n-k-3) U_{n,r,0,k}, \tag{8.29}$$

and those from $[[C^i], [C^{n-i}]]$ are

$$k_{i+1} k_{n-i} \left(\sum_{r=0}^{i-3} \sum_{k=0}^{i-r-3} U_{n,r,n-i-2,k} - \sum_{r=0}^{i-2} \sum_{k=0}^{n-i-3} U_{n,r,0,k} - \sum_{r=i-1}^{n-5} \sum_{k=0}^{n-r-5} U_{n,r,0,k} \right). \tag{8.30}$$

To these contributions must be added the remainder term corresponding to the first term on the right hand side of Eq. (8.26), with the appropriate coefficients from Eq. (8.27). Let $U_{n,r,j,k}$ correspond to the monomial $s^j t^k u^r$. According to Eq. (8.26), the remainder terms then become

$$u^{n-5} \frac{\phi_n\left(\frac{s}{u}, \frac{t}{u}\right)}{\frac{s}{u} + \frac{t}{u} - 1} \approx \frac{u^{n-4}}{1-u} \phi_n\left(\frac{s}{u}, \frac{t}{u}\right), \tag{8.31}$$

where $\phi(s, t, x) = \sum_{n=2}^{\infty} \phi_n(s, t) x^n$, and where $s + t - 1 \approx 0$ has been used in the last step. The total contribution to the n -bracket identity then is

$$\begin{aligned} & \frac{1}{2} \left[k_n \left(- \sum_{r=0}^{n-5} \sum_{k=0}^{n-r-5} (n-k-3) u^r t^k - \frac{u^{n-4}}{1-u} \sum_{k=0}^{n-4} (n-k-3) \left(\frac{t}{u}\right)^k \right) \right. \\ & + \sum_{i=1}^{n-2} k_{i+1} k_{n-i} \left(\sum_{r=0}^{i-3} \sum_{k=0}^{i-r-3} s^{n-i-2} t^k u^r - \sum_{r=0}^{i-2} \sum_{k=0}^{n-i-3} t^k u^r - \sum_{r=i-1}^{n-5} \sum_{k=0}^{n-r-5} t^k u^r \right) \\ & + \left. \frac{u^{n-4}}{1-u} \sum_{k=0}^{i-2} \left(\frac{s}{u}\right)^{n-i-2} \left(\frac{t}{u}\right)^k - \frac{u^{n-4}}{1-u} \sum_{k=0}^{n-i-3} \left(\frac{t}{u}\right)^k \right] + (s \leftrightarrow t) \\ & = \frac{1}{2} \left[-k_n \frac{n-3-(n-2)t+t^{n-2}}{(1-t)^2(1-u)} \right. \\ & + \left. \sum_{i=1}^{n-2} k_{i+1} k_{n-i} \frac{(1-t^{i-1})s^{n-i-2} - (1-t^{n-i-2})}{(1-t)(1-u)} \right] + (s \leftrightarrow t) \\ & = \frac{\phi_n(s, t)}{1-u}. \tag{8.32} \end{aligned}$$

The $U_{n,r,s,t}$ terms thus cancel for all values of r .

The terms of type $V_{n,r,s,t}$ obtained directly from $[[[C^n]]] + n[[C^{n-1}, [C]]]$ are

$$-k_n \sum_{r=0}^{n-5} \sum_{k=0}^{n-r-5} (n-r-k-4) V_{n,r,0,k} \tag{8.33}$$

and the ones from $[[C^i, [C^{n-i}]]]$ are

$$\begin{aligned} & k_{i+1} k_{n-i} \left(- \sum_{r=0}^{n-i-4} \sum_{k=0}^{n-i-r-4} V_{n,r,0,k} + \sum_{j=0}^{i-2} \sum_{k=0}^{n-i-3} V_{n,n-i-k-3,j,k} \right. \\ & \left. + \sum_{r=0}^{i-3} \sum_{k=0}^{i-r-3} V_{n,r,n-i-2,k} \right). \tag{8.34} \end{aligned}$$

In addition, there is a remainder term from the second term on the right hand side of Eq. (8.26). If $V_{n,r,j,k}$ is represented by $s^j t^k u^r$, the remainder term becomes

$$-2 \frac{\phi_n(s, u)}{s+u-1}. \tag{8.35}$$

The total contribution of terms of type V to the n -bracket is then represented by the function $v_n(s, t, u)$:

$$\begin{aligned}
 v_n(s, t, u) = & -k_n \sum_{r=0}^{n-5} \sum_{k=0}^{n-r-5} (n-r-k-4)t^k u^r \\
 & + \sum_{i=1}^{n-2} k_{i+1} k_{n-i} \left(- \sum_{r=0}^{n-i-4} \sum_{k=0}^{n-i-r-4} t^k u^r + \sum_{j=0}^{i-2} \sum_{k=0}^{n-i-3} s^j t^k u^{n-i-k-3} \right. \\
 & \left. + \sum_{r=0}^{i-3} \sum_{k=0}^{i-r-3} s^{n-i-2} t^k u^r \right) \\
 & + \frac{1}{s+u-1} \left[k_n \sum_{\ell=0}^{n-4} (n-\ell-3)(s^\ell + u^\ell) \right. \\
 & \left. + \sum_{i=1}^{n-2} k_{i+1} k_{n-i} \left(\sum_{\ell=0}^{n-i-3} (s^\ell + u^\ell) - \sum_{\ell=0}^{i-2} (s^{n-i-2} u^\ell + s^\ell u^{n-i-2}) \right) \right]. \tag{8.36}
 \end{aligned}$$

Performing the sums, except the ones over i , and replacing s by $1-t$, this function turns into

$$v_n(1-t, t, u) = 2 \frac{\phi_n(1-t, t)}{t-u}. \tag{8.37}$$

Therefore, these terms cancel. Note that the symmetrisation $s \leftrightarrow t$ in ϕ_n is automatic, and not imposed by hand. This concludes the proof that all the identities are satisfied.

The series $\sum_{n=2}^\infty k_n (\text{ad } C)^{n-2}$ appearing in the variation of the ghosts, the sum of all brackets, can be written in the concise form $g(\text{ad } C)$, where $g(x) = \frac{2}{1-e^{-2x}} - \frac{1}{x}$. Likewise, the sum $\sum_{n=2}^\infty \frac{k_n}{n} (\text{ad } C)^{n-2}$ becomes $h(\text{ad } C)$, where

$$h(x) = \frac{1}{x^2} \int_0^x dy y g(y) = 1 - \frac{1}{x} + \log(1 - e^{-2x}) - \frac{1}{x^2} (\text{Li}_2(e^{-2x}) - \frac{\pi^2}{12}). \tag{8.38}$$

The terms in the brackets containing sums of type $\sum_{i=0}^{n-3} (\text{ad } C)^i \mathcal{O}(\text{ad } C)^{n-i-3}$ can be formally rewritten, e.g.,

$$\begin{aligned}
 \sum_{n=2}^\infty k_n \sum_{i=0}^{n-3} (\text{ad } C)^i \mathcal{O}(\text{ad } C)^{n-i-3} &= \sum_{n=2}^\infty k_n \frac{(\text{ad } C)_L^{n-2} - (\text{ad } C)_R^{n-2}}{(\text{ad } C)_L - (\text{ad } C)_R} \mathcal{O} \\
 &= \frac{g((\text{ad } C)_L) - g((\text{ad } C)_R)}{(\text{ad } C)_L - (\text{ad } C)_R} \mathcal{O}, \tag{8.39}
 \end{aligned}$$

where subscripts L, R stands for action to the left or to the right of the succeeding operator (\mathcal{O}). Then, the full ghost variation takes the functional form

$$\begin{aligned}
 (S, C + K) = & (d + \flat)(C + K) + g(\text{ad } C)(\mathcal{L}_C + X_C)C + h(\text{ad } C)\mathcal{L}_C K \\
 & + \left[\frac{g((\text{ad } C)_L) - g((\text{ad } C)_R)}{(\text{ad } C)_L - (\text{ad } C)_R} R_C \right] \mathcal{L}_C C + \left[\frac{h((\text{ad } C)_L) - h((\text{ad } C)_R)}{(\text{ad } C)_L - (\text{ad } C)_R} \text{ad } K \right] \mathcal{L}_C C. \tag{8.40}
 \end{aligned}$$

9. Examples

The criterion that no ancillary transformations appear in the commutator of two generalised diffeomorphisms is quite restrictive. It was shown in ref. [2] that this happens if and only if \mathfrak{g}_r is finite-dimensional and the derivative module is $R(\lambda)$ where λ is a fundamental weight dual to a simple root with Coxeter label 1. The complete list is

- (i) $\mathfrak{g}_r = A_r, \lambda = \Lambda_p, p = 1, \dots, r$ (p -form representations);
- (ii) $\mathfrak{g}_r = B_r, \lambda = \Lambda_1$ (the vector representation);
- (iii) $\mathfrak{g}_r = C_r, \lambda = \Lambda_r$ (the symplectic-traceless r -form representation);
- (iv) $\mathfrak{g}_r = D_r, \lambda = \Lambda_1, \Lambda_{r-1}, \Lambda_r$ (the vector and spinor representations);
- (v) $\mathfrak{g}_r = E_6, \lambda = \Lambda_1, \Lambda_5$ (the fundamental representations);
- (vi) $\mathfrak{g}_r = E_7, \lambda = \Lambda_1$ (the fundamental representation).

If \mathfrak{g}_{r+1} has a 5-grading or higher with respect to the subalgebra \mathfrak{g}_r (in particular, if it is infinite-dimensional), \tilde{R}_2 will be non-empty (see Table 1), and there will be ancillary ghosts starting from level 1 (ghost number 2).

Ordinary diffeomorphisms provide a simple and quite degenerate example, where $\mathfrak{g}_r = A_r$ and $\lambda = \Lambda_1$. In this case, both R_2 and \tilde{R}_2 are empty, so both \mathfrak{g}_{r+1} and $\mathcal{B}(\mathfrak{g}_r)$ are 3-gradings. Still, the example provides the core of all other examples. The algebra of vector fields in $r + 1$ dimensions is constructed using the structure constants of

$$\mathcal{B}(A_{r+1}) \approx A(r + 1|0) \approx \mathfrak{sl}(r + 2|1). \tag{9.1}$$

There is of course neither any reducibility nor any ancillary ghosts, and the only ghosts are the ones in the vector representation \mathbf{v} in $R_{(1,0)}$. The double grading of the superalgebra is given in Table 3.

The double diffeomorphisms, obtained from $\mathfrak{g}_r = D_r$, have a singlet reducibility, and no ancillary transformations. The L_∞ structure (truncating to an L_3 algebra) was examined in ref. [21]. The Borchers superalgebra is finite-dimensional,

$$\mathcal{B}(D_{r+1}) \approx D(r + 1|0) \approx \mathfrak{osp}(r + 1, r + 1|2). \tag{9.2}$$

The double grading of this superalgebra is given in Table 4. The only ghosts are the (double) vector in $R_{(1,0)}$ and the singlet in $R_{(2,0)}$.

The extended geometry based on $\mathfrak{g}_r = B_r$ follows an analogous pattern, and is also described by Table 4, but with the doubly extended algebra $B(r+1, 0) \approx \mathfrak{osp}(r+1, r+2|2)$ being decomposed into modules of $B(r) \approx \mathfrak{so}(r, r + 1)$.

Together with the ordinary diffeomorphisms, these are the only cases with finite reducibility and without ancillary transformations at ghost number 1. In order for the reducibility to be finite, it is necessary that $\mathcal{B}(\mathfrak{g}_r)$ is finite-dimensional. The remaining finite-dimensional superalgebras in the classification by Kac [51] are not represented by Dynkin diagrams where the grey node connects to a node with Coxeter label 1. Therefore, even if there are other examples with finite-dimensional $\mathcal{B}(\mathfrak{g}_r)$, they all have ancillary transformations appearing in the commutator of two generalised Lie derivatives. Such

Table 3. The decomposition of $A(r + 1|0) \approx \mathfrak{sl}(r + 2|1)$ in $A(r) \approx \mathfrak{sl}(r + 1)$ modules

	$p = -1$	$p = 0$	$p = 1$
$q = 1$		$\mathbf{1}$	\mathbf{v}
$q = 0$	$\bar{\mathbf{v}}$	$\mathbf{1} \oplus \mathbf{adj} \oplus \mathbf{1}$	\mathbf{v}
$q = -1$	$\bar{\mathbf{v}}$	$\mathbf{1}$	

Table 4. The decomposition of $D(r + 1|0) \approx \mathfrak{osp}(r + 1, r + 1|2)$ in $D(r) \approx \mathfrak{so}(r, r)$ modules

	$p = -2$	$p = -1$	$p = 0$	$p = 1$	$p = 2$
$q = 1$			1	v	1
$q = 0$	1	v	1 \oplus adj \oplus 1	v	1
$q = -1$	1	v	1		

Table 5. Part of the decomposition of $\mathcal{B}(E_{6(6)})$ in $E_{5(5)} \approx \mathfrak{so}(5, 5)$ modules. Note the appearance of modules \tilde{R}_p for $p \geq 4$

	$p = -1$	$p = 0$	$p = 1$	$p = 2$	$p = 3$	$p = 4$	$p = 5$
$q = 2$						1	16
$q = 1$		1	16	10	$\overline{\mathbf{16}}$	45 \oplus 1	$\overline{\mathbf{144}} \oplus \mathbf{16}$
$q = 0$	$\overline{\mathbf{16}}$	1 \oplus 45 \oplus 1	16	10	$\overline{\mathbf{16}}$	45	$\overline{\mathbf{144}}$
$q = -1$	$\overline{\mathbf{16}}$	1					

Table 6. Part of the decomposition of $\mathcal{B}(E_{8(8)})$ in $E_{7(7)}$ modules

	$p = 0$	$p = 1$	$p = 2$	$p = 3$	$p = 4$
$q = 3$					1
$q = 2$			1	56	1539 \oplus 133 \oplus $2 \cdot \mathbf{1}$
$q = 1$	1	56	133 \oplus 1	912 \oplus 56	8645 \oplus $2 \cdot \mathbf{133} \oplus \mathbf{1539} \oplus \mathbf{1}$
$q = 0$	1 \oplus 133 \oplus 1	56	133	912	8645 \oplus 133
$q = -1$	1				

Table 7. Part of the decomposition of R_p for the $E_{5(5)}$ exceptional geometry with respect to a section $\mathfrak{sl}(5)$

	$p = 1$	$p = 2$	$p = 3$	$p = 4$	$p = 5$	$p = 6$
$v = 6$						$(\overline{\mathbf{15}} \oplus \mathbf{40}) \otimes \Lambda_5$
$v = 5$					24 \otimes Λ_5	24 \otimes $\Lambda_4 \oplus (\mathbf{5} \oplus \overline{\mathbf{45}}) \otimes \Lambda_5$
$v = 4$				10 \otimes Λ_5	10 \otimes $\Lambda_4 \oplus \overline{\mathbf{15}}$ \otimes Λ_5	10 \otimes $\Lambda_3 \oplus \overline{\mathbf{15}}$ \otimes $\Lambda_4 \oplus \mathbf{5} \otimes \Lambda_5$
$v = 3$			$\overline{\mathbf{5}} \otimes \Lambda_5$	$\overline{\mathbf{5}} \otimes \Lambda_4$	$\overline{\mathbf{5}} \otimes \Lambda_3$	$\overline{\mathbf{5}} \otimes \Lambda_2$
$v = 2$	Λ_5	Λ_4	Λ_3	Λ_2	Λ_1	Λ_0
$v = 1$	Λ_2	Λ_1	Λ_0			
$v = 0$	Λ_4					

The derivative acts horizontally to the left and Λ_k denote the k -form modules of $\mathfrak{sl}(5)$, such that $\Lambda_1, \Lambda_2, \dots = \overline{\mathbf{5}}, \mathbf{10}, \dots$ and $\Lambda_0 = \Lambda_5 = \mathbf{1}$. The degree v is such that the relative weights in the extension to $\mathfrak{gl}(5)$ are given by $3v + 4p$. The Λ_4 in the lower left corner is the vector module corresponding to the ordinary coordinates with this choice of section

examples may be interesting to investigate in the context of the tensor hierarchy algebra (see the discussion in Section 10).

We now consider the cases $\mathfrak{g}_r = E_r$ for $r \leq 7$. The level decompositions of the Borchers superalgebras are described in Ref. [4]. There are always ancillary ghosts, starting at level $8 - r$ (ghost number $9 - r$). In Table 5, we give the double grading in the example $\mathfrak{g}_r = E_{5(5)} \approx \mathfrak{so}(5, 5)$. Modules \tilde{R}_p are present for $p \geq 4$, signalling an infinite tower of ancillary ghost from ghost number 4. Table 6 gives the corresponding decomposition for $\mathfrak{g}_r = E_{7(7)}$. This is as far as the construction of the present paper applies. Note that for $\mathfrak{g}_r = E_{7(7)}$ already $\tilde{R}_2 = \mathbf{1}$, which leads to ancillary ghosts in the **56** at $(p, q) = (1, 1)$.

In Table 7, we have divided the modules R_p for the $E_{5(5)}$ example of Table 5 into A_4 modules with respect to a choice of section. Below the solid dividing line are the usual sequences of ghosts for diffeomorphisms and 2-form and 5-form gauge transformations. Above the line are sequences that contain tensor products of forms with some other

modules, *i.e.*, mixed tensors. All modules above the line are effectively cancelled by the ancillary ghosts. They are however needed to build modules of \mathfrak{g}_r . In the example, there is nothing below the line for $p \geq 7$, which means that the \flat operation from ancillary to non-ancillary ghosts at these levels becomes bijective.

Reducibility is of course not an absolute concept; it can depend on the amount of covariance maintained. If a section is chosen, the reducibility can be made finite by throwing away all ghosts above the dividing line. One then arrives at the situation in ref. [42]. If full covariance is maintained, reducibility is infinite. Since the modules above the line come in tensor products of some modules with full sets of forms of alternating statistics, they do not contribute to the counting of the degrees of freedom. This shows why the counting of refs. [1,4], using only the non-ancillary ghosts, gives the correct counting of the number of independent gauge parameters.

This picture of the reduction of the modules R_p in a grading with respect to the choice of section also makes the characterisation of ancillary ghosts clear. They are elements in R_p above a certain degree (for which the degree of the derivative is 0). The dotted line in the table indicates degree 0. If we let \mathcal{A} be the subalgebra of ancillary elements above the solid line, it is clear that \mathcal{A} forms an ideal in $\mathcal{B}_+(\mathfrak{g}_r)$ (which was also shown on general grounds in Section 7). The grading coincides with the grading used in ref. [2] to show that the commutator of two ancillary transformations again is ancillary.

As an aside, the regularised dimension, twisted with fermion number, of $\mathcal{B}_+(\mathfrak{g}_{r+1})$ can readily be calculated using the property that all modules at $p \neq 0$ come in doublets under the superalgebra generated by e and f , without need of any further regularisation (*e.g.* through analytic continuation). Using the cancellation of these doublets, inspection of Table 1 gives at hand that the “super-dimension” (where fermionic generators count with a minus sign)

$$\begin{aligned}
 -\text{sdim}(\mathcal{B}_+(\mathfrak{g}_{r+1})) &= 1 + \dim(R_1) + \dim(\tilde{R}_2) + \dim(\tilde{R}_3) + \dots \\
 &= 1 + \dim(\mathfrak{g}_{r+1,+}),
 \end{aligned}
 \tag{9.3}$$

where $\mathfrak{g}_{r+1,+}$ is the positive level part of the grading of \mathfrak{g}_{r+1} with respect to \mathfrak{g}_r . This immediately reproduces the counting of the effective number of gauge transformations in ref. [1]. In the example $\mathcal{B}(E_6)$ above, we get $1+16 = 17$, which is the correct counting of gauge parameters for diffeomorphisms, 2- and 5-form gauge transformations in 6 dimensions.

10. Conclusions

We have provided a complete set of bracket giving an L_∞ algebra for generalised diffeomorphisms in extended geometry, including double geometry and exceptional geometry as special cases. The construction depends crucially on the use of the underlying Borchers superalgebra $\mathcal{B}(\mathfrak{g}_{r+1})$, which is a double extension of the structure algebra \mathfrak{g}_r . This superalgebra is needed in order to form the generalised diffeomorphisms, and has a natural interpretation in terms of the section constraint. It also provides a clear criterion for the appearance of ancillary ghosts.

The full list of non-vanishing brackets is:

$$\begin{aligned} \llbracket C \rrbracket &= dC, \\ \llbracket K \rrbracket &= dK + K^b, \\ \llbracket C^n \rrbracket &= k_n \left((\text{ad } C)^{n-2} (\mathcal{L}_C C + X_C C) + \sum_{i=0}^{n-3} (\text{ad } C)^i R_C (\text{ad } C)^{n-i-3} \mathcal{L}_C C \right) \\ \llbracket C^{n-1}, K \rrbracket &= \frac{k_n}{n} \left((\text{ad } C)^{n-2} \mathcal{L}_C K + \sum_{i=0}^{n-3} (\text{ad } C)^i \text{ad } K (\text{ad } C)^{n-i-3} \mathcal{L}_C C \right), \end{aligned} \tag{10.1}$$

where the coefficients have the universal model-independent expression in terms of Bernoulli numbers

$$k_{n+1} = \frac{2^n B_n^+}{n!}, \quad n \geq 1. \tag{10.2}$$

All non-vanishing brackets except the 1-bracket contain at least one level 1 ghost c . No brackets contain more than one ancillary ghost.

The violation of covariance of the derivative, that modifies already the 2-bracket, has a universal form, encoded in X_C in Eq. (4.14). It is not unlikely that this makes it possible to covariantise the whole structure, as in ref. [39]. However, we think that it is appropriate to let the algebraic structures guide us concerning such issues.

The characterisation of ancillary ghosts is an interesting issue, that may deserve further attention. Even if the construction in Section 7 makes the appearance of ancillary ghosts clear (from the existence of modules \tilde{R}_p) it is indirect and does not contain an independent characterisation of the ancillary ghosts, in terms of a constraint. This property is shared with the construction of ancillary transformations in ref. [40]. The characterisation in Section 9 in terms of the grading induced by a choice of section is a direct one, in this sense, but has the drawback that it lacks full covariance. In addition, there may be more than one possible choice of section. This issue may become more important when considering situations with ancillary ghosts at ghost number 1 (see below). Then, with the exception of some simpler cases with finite-dimensional \mathfrak{g}_r , ancillary transformations are not expected to commute.

We have explicitly excluded from our analysis cases where ancillary transformations appear already at ghost number 1 [38–40, 52]. The canonical example is exceptional geometry with structure group $E_{8(8)}$. If we should trust and extrapolate the results of the present paper, this would correspond to the presence of a module \tilde{R}_1 . However, there is never such a module in the Borchers superalgebra. If we instead turn to the tensor hierarchy algebra [53–55] we find that a module \tilde{R}_1 indeed appears in cases when ancillary transformations are present in the commutator of two generalised diffeomorphisms.

As an example, Table 8 contains a part of the double grading of the tensor hierarchy algebra $W(E_9)$ (following the notation of ref. [54]), which we believe should be used in the construction of an L_∞ algebra for E_8 generalised diffeomorphisms. The E_8 modules that are not present in the $\mathcal{B}(E_9)$ superalgebra are marked in blue colour. The singlet at $(p, q) = (1, 1)$ is the extra element appearing at level 0 in $W(E_9)$ that can be identified with the Virasoro generator L_1 (as can be seen in the decomposition under $\mathfrak{gl}(9)$ [55]). The elements at $q - p = 1$ come from the “big” module at level -1 in $W(E_9)$ (the embedding tensor or big torsion module). For an affine \mathfrak{g}_{r+1} this is a shifted fundamental highest weight module, with its highest weight at $(p, q) = (1, 2)$, appearing in $W(\mathfrak{g}_{r+1})$

Table 8. Part of the decomposition of the tensor hierarchy algebra $W(E_9)$ into E_8 modules. The modules not present in $\mathcal{B}(E_9)$ are marked italic

	$p = -1$	$p = 0$	$p = 1$	$p = 2$
$q = 2$			I	248
$q = 1$	$I \oplus 3875 \oplus 248$	$1 \oplus 248$	$248 \oplus I$	$1 \oplus 3875 \oplus 248$
$q = 0$	$248 \oplus I \oplus 3875 \oplus 248$	$1 \oplus 248 \oplus 1$	248	$1 \oplus 3875$
$q = -1$	248	1		

Note the presence of $\tilde{R}_1 = 1$

in addition to the unshifted one with highest weight at $(p, q) = (0, 1)$ appearing also in the Borchers superalgebra $\mathcal{B}(\mathfrak{g}_{r+1})$. In the E_8 example, it contains the **248** at $(p, q) = (0, 1)$ which will accommodate parameters of the ancillary transformations. In situations when ancillary transformations are absent at ghost number 1 (the subject of the present paper), using $W(\mathfrak{g}_{r+1})$ is equivalent to using $\mathcal{B}(\mathfrak{g}_{r+1})$, so all results derived here will remain unchanged.

We take this as a very strong sign that the tensor hierarchy algebra is the correct underlying algebra, and hope that a generalisation of the present approach to the use of an underlying tensor hierarchy algebra will shed new light on the properties of generalised diffeomorphisms in situations where ancillary transformations are present.

Acknowledgements We would like to thank David Berman and Charles Strickland-Constable for collaboration in an early stage of this project. We also acknowledge discussions with Alex Arvanitakis, Klaus Bering, Olaf Hohm, and Barton Zwiebach. This research is supported by the Swedish Research Council, project no. 2015-04268.

Open Access This article is distributed under the terms of the Creative Commons Attribution 4.0 International License (<http://creativecommons.org/licenses/by/4.0/>), which permits unrestricted use, distribution, and reproduction in any medium, provided you give appropriate credit to the original author(s) and the source, provide a link to the Creative Commons license, and indicate if changes were made.

Publisher's Note Springer Nature remains neutral with regard to jurisdictional claims in published maps and institutional affiliations.

References

- Berman, D.S., Cederwall, M., Kleinschmidt, A., Thompson, D.C.: The gauge structure of generalised diffeomorphisms. *JHEP* **01**, 064 (2013). [arXiv:1208.5884](https://arxiv.org/abs/1208.5884)
- Cederwall, M., Palmkvist, J.: Extended geometries. *JHEP* **02**, 071 (2018). [arXiv:1711.07694](https://arxiv.org/abs/1711.07694)
- Palmkvist, J.: Exceptional geometry and Borchers superalgebras. *JHEP* **11**, 032 (2015). [arXiv:1507.08828](https://arxiv.org/abs/1507.08828)
- Cederwall, M., Palmkvist, J.: Superalgebras, constraints and partition functions. *JHEP* **08**, 036 (2015). [arXiv:1503.06215](https://arxiv.org/abs/1503.06215)
- Tseytlin, A.A.: Duality symmetric closed string theory and interacting chiral scalars. *Nucl. Phys. B* **350**, 395–440 (1991)
- Siegel, W.: Two vierbein formalism for string inspired axionic gravity. *Phys. Rev. D* **47**, 5453–5459 (1993). [arXiv:hep-th/9302036](https://arxiv.org/abs/hep-th/9302036)
- Siegel, W.: Manifest duality in low-energy superstrings. In International Conference on Strings 93 Berkeley, California, May 24–29, 1993, pp. 353–363 (1993). [arXiv:hep-th/9308133](https://arxiv.org/abs/hep-th/9308133)
- Hitchin, N.: Lectures on generalized geometry. [arXiv:1008.0973](https://arxiv.org/abs/1008.0973)
- Hull, C.M.: A geometry for non-geometric string backgrounds. *JHEP* **10**, 065 (2005). [arXiv:hep-th/0406102](https://arxiv.org/abs/hep-th/0406102)
- Hull, C.M.: Doubled geometry and T-folds. *JHEP* **07**, 080 (2007). [arXiv:hep-th/0605149](https://arxiv.org/abs/hep-th/0605149)
- Hull, C., Zwiebach, B.: Double field theory. *JHEP* **09**, 099 (2009). [arXiv:0904.4664](https://arxiv.org/abs/0904.4664)
- Hohm, O., Hull, C., Zwiebach, B.: Background independent action for double field theory. *JHEP* **07**, 016 (2010). [arXiv:1003.5027](https://arxiv.org/abs/1003.5027)

13. Hohm, O., Hull, C., Zwiebach, B.: Generalized metric formulation of double field theory. JHEP **08**, 008 (2010). [arXiv:1006.4823](#)
14. Jeon, I., Lee, K., Park, J.-H., Suh, Y.: Stringy unification of type IIA and IIB supergravities under $N = 2$ $D = 10$ supersymmetric double field theory. Phys. Lett. B **723**, 245–250 (2013). [arXiv:1210.5078](#)
15. Park, J.-H.: Comments on double field theory and diffeomorphisms. JHEP **06**, 098 (2013). [arXiv:1304.5946](#)
16. Berman, D.S., Cederwall, M., Perry, M.J.: Global aspects of double geometry. JHEP **09**, 066 (2014). [arXiv:1401.1311](#)
17. Cederwall, M.: The geometry behind double geometry. JHEP **09**, 070 (2014). [arXiv:1402.2513](#)
18. Cederwall, M.: T-duality and non-geometric solutions from double geometry. Fortsch. Phys. **62**, 942–949 (2014). [arXiv:1409.4463](#)
19. Cederwall, M.: Double supergeometry. JHEP **06**, 155 (2016). [arXiv:1603.04684](#)
20. Deser, A., Sämann, C.: Extended Riemannian geometry I: local double field theory. [arXiv:1611.02772](#)
21. Hohm, O., Zwiebach, B.: L_∞ algebras and field theory. Fortsch. Phys. **65**, 1700014 (2017). [arXiv:1701.08824](#)
22. Deser, A., Sämann, C.: Derived brackets and symmetries in generalised geometry and double field theory. In 17th Hellenic School and Workshops on Elementary Particle Physics and Gravity (CORFU2017) Corfu, Greece, September 2–28, 2017. (2018). [arXiv:1803.01659](#)
23. Hull, C.: Generalised geometry for M-theory. JHEP **0707**, 079 (2007). [arXiv:hep-th/0701203](#)
24. Pacheco, P.P., Waldram, D.: M-theory, exceptional generalised geometry and superpotentials. JHEP **0809**, 123 (2008). [arXiv:0804.1362](#)
25. Hillmann, C.: $E_{7(7)}$ and $d = 11$ supergravity. [arXiv:0902.1509](#). PhD thesis, Humboldt-Universität zu Berlin (2008)
26. Berman, D.S., Perry, M.J.: Generalized geometry and M theory. JHEP **1106**, 074 (2011). [arXiv:1008.1763](#)
27. Berman, D.S., Godazgar, H., Perry, M.J.: $SO(5, 5)$ duality in M-theory and generalized geometry. Phys. Lett. B **700**, 65–67 (2011). [arXiv:1103.5733](#)
28. Coimbra, A., Strickland-Constable, C., Waldram, D.: $E_{d(d)} \times \mathbb{R}^+$ generalised geometry, connections and M theory. JHEP **1402**, 054 (2014). [arXiv:1112.3989](#)
29. Coimbra, A., Strickland-Constable, C., Waldram, D.: Supergravity as generalised geometry II: $E_{d(d)} \times \mathbb{R}^+$ and M theory. JHEP **1403**, 019 (2014). [arXiv:1212.1586](#)
30. Park, J.-H., Suh, Y.: U-geometry : $SL(5)$. JHEP **04**, 147 (2013). [arXiv:1302.1652](#)
31. Cederwall, M., Edlund, J., Karlsson, A.: Exceptional geometry and tensor fields. JHEP **07**, 028 (2013). [arXiv:1302.6736](#)
32. Cederwall, M.: Non-gravitational exceptional supermultiplets. JHEP **07**, 025 (2013). [arXiv:1302.6737](#)
33. Aldazabal, G., Graña, M., Marqués, D., Rosabal, J.: Extended geometry and gauged maximal supergravity. JHEP **1306**, 046 (2013). [arXiv:1302.5419](#)
34. Hohm, O., Samtleben, H.: Exceptional form of $D = 11$ supergravity. Phys. Rev. Lett. **111**, 231601 (2013). [arXiv:1308.1673](#)
35. Blair, C.D., Malek, E., Park, J.-H.: M-theory and type IIB from a duality manifest action. JHEP **1401**, 172 (2014). [arXiv:1311.5109](#)
36. Hohm, O., Samtleben, H.: Exceptional field theory I: $E_{6(6)}$ covariant form of M-theory and type IIB. Phys. Rev. D **89**, 066016 (2014). [arXiv:1312.0614](#)
37. Hohm, O., Samtleben, H.: Exceptional field theory II: $E_{7(7)}$. Phys. Rev. D **89**, 066017 (2014). [arXiv:1312.4542](#)
38. Hohm, O., Samtleben, H.: Exceptional field theory. III. $E_{8(8)}$. Phys. Rev. D **90**, 066002 (2014). [arXiv:1406.3348](#)
39. Cederwall, M., Rosabal, J.A.: E_8 geometry. JHEP **07**, 007 (2015). [arXiv:1504.04843](#)
40. Bossard, G., Cederwall, M., Kleinschmidt, A., Palmkvist, J., Samtleben, H.: Generalized diffeomorphisms for E_9 . Phys. Rev. D **96**, 106022 (2017). [arXiv:1708.08936](#)
41. Wang, Y.-N.: Generalized Cartan calculus in general dimension. JHEP **07**, 114 (2015). [arXiv:1504.04780](#)
42. Baraglia, D.: Leibniz algebroids, twistings and exceptional generalized geometry. J. Geom. Phys. **62**, 903–934 (2012). [arXiv:1101.0856](#)
43. Dobrev, V.K., Petkova, V.B.: Group theoretical approach to extended conformal supersymmetry: Function space realizations and invariant differential operators. Fortsch. Phys. **35**, 537 (1987)
44. Batalin, I.A., Vilkovisky, G.A.: Gauge algebra and quantization. Phys. Lett. **102B**, 27–31 (1981)
45. Lada, T., Stasheff, J.: Introduction to SH Lie algebras for physicists. Int. J. Theor. Phys. **32**, 1087–1104 (1993). [arXiv:hep-th/9209099](#)
46. Zwiebach, B.: Closed string field theory: quantum action and the B–V master equation. Nucl. Phys. B **390**, 33–152 (1993). [arXiv:hep-th/9206084](#)
47. Roytenberg, D., Weinstein, A.: Courant algebroids and strongly homotopy Lie algebras. [arXiv:math/9802118](#)

48. Stasheff, J.: The (Secret?) homological algebra of the Batalin–Vilkovisky approach. *Contemp. Math.* **219**, 195–210 (1998). [arXiv:hep-th/9712157](#)
49. Bering, K.: On non-commutative Batalin–Vilkovisky algebras, strongly homotopy Lie algebras and the Courant bracket. *Commun. Math. Phys.* **274**, 297–341 (2007). [arXiv:hep-th/0603116](#)
50. Getzler, E.: Higher derived brackets. [arXiv:1010.5859](#)
51. Kac, V.G.: Lie superalgebras. *Adv. Math.* **26**, 8–96 (1977)
52. Hohm, O., Samtleben, H.: U-duality covariant gravity. *JHEP* **09**, 080 (2013). [arXiv:1307.0509](#)
53. Palmkvist, J.: The tensor hierarchy algebra. *J. Math. Phys.* **55**, 011701 (2014). [arXiv:1305.0018](#)
54. Carbone, L., Cederwall, M., Palmkvist, J.: Generators and relations for Lie superalgebras of Cartan type (to appear in *J. Phys. A*) [arXiv:1802.05767](#)
55. Bossard, G., Kleinschmidt, A., Palmkvist, J., Pope, C.N., Sezgin, E.: Beyond E_{11} . *JHEP* **05**, 020 (2017). [arXiv:1703.01305](#)

Communicated by C. Schweigert