



Abstraction models for 5G mobile networks integration into industrial networks and their evaluation

Arne Neumann¹, Lukasz Wisniewski¹, Torsten Musiol², Christian Mannweiler³,
Borislava Gajic³, Rakash SivaSiva Ganesan³, Peter Rost³

¹inIT - Institute Industrial IT
Technische Hochschule Ostwestfalen-Lippe
Campusallee 6, 32657 Lemgo
{arne.neumann, lukasz.wisniewski}@th-owl.de

²MECSware GmbH
Blumenstr. 48, 42549 Velbert
torsten.musiol@mecsware.com

³Nokia Bell Labs
Werinherstrasse 91, 81541 München
{christian.mannweiler, borislava.gajic, rakash.sivasivaganesan,
peter.m.rost}@nokia-bell-labs.com

Abstract. The fifth generation of mobile networks (5G) will provide capabilities for its utilization in the communication in production systems. For several technical and commercial reasons, complementing industrial wired and wireless communication technology by 5G is more likely than replacing them completely [WSJ17]. This paper sketches abstraction models of 5G networks for their integration into industrial networks. Dependabilities from the type of the industrial network, constraints of the models and the impact of the resulting architecture to data plane and control plane of the overall hybrid network will be discussed. In addition, metrics for the evaluation of the modeling approaches from an end-to-end user application perspective will be figured out.

1 Introduction

The currently ongoing specification of the fifth generation of mobile networks [RBB⁺16] addresses massive machine-type communication, ultra reliability (99,999%) and low latency (less than 1ms) in addition to enhanced mobile broadband which has been the target of mobile networks evolution from its beginning. Therefore 5G gains interest from the industry, thus initiatives trying to integrate 5G in the industrial automation domain, such as 5G Alliance for Connected Industries and Automation (5G-ACIA) has been started [5G 18].

For the modeling of the integration of 5G networks into industrial networks, this paper focuses on wired technologies in the area of industrial networks. Wireless technologies, such as IEEE based standards or technologies coming from the

ZDKI research program of the BMBF [Fac17] are subject of approaches of the reverse integration strategy, i.e. integration of industrial wireless into 5G, in current research and specification, such as in [YPMP17]. They are considered as complementing technologies in the radio access network (RAN) of 5G in this context. Furthermore, in the area of wired industrial communication, this paper focuses on Ethernet based technologies since they gained the highest importance in application and represent themselves as an integration platform of other industrial access protocols like IO-Link, AS-i, Profibus, and HART. Industrial Ethernet technologies show a broad variety. Some of them add functionality such as summation frame communication or Time Division Multiple Access (TDMA) to the lower protocol layers in order to fulfill real-time requirements of the field level communication. Other technologies are focusing on interoperability at control and factory level utilizing the full standard TCP/IP stack. An example for this is OPC UA. This variety suggests to consider different integration approaches for mobile networks.

There are different application possibilities to integrate a 5G mobile network into an industrial Ethernet system as described in [NWG⁺18]. The possibilities are resulting from the variety of applicable use cases. Some use cases with a high relevance in the scope of future factories are introduced in [GSS⁺18]. They include cooperative transport of goods, closed loop control, additive sensing and remote control in process automation, and industrial campus. The dif-

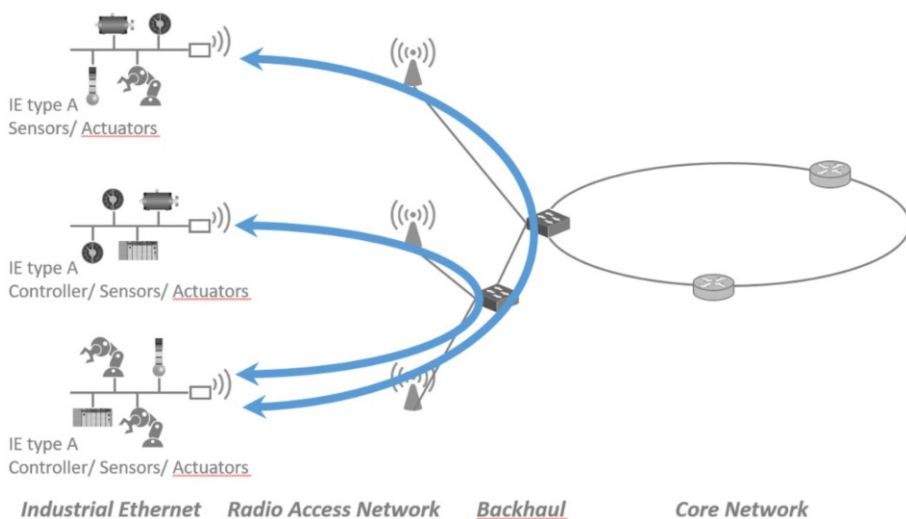

Fig. 1. Integration scenario of connected industrial islands acc. to [NWG⁺18]

ferences in the integration scenarios mainly concern (i) the spatial extent of the networked equipment, i.e. whether industrial system is local or geographically

wide distributed, (ii) the uniformity of the Industrial Ethernet technology, i.e., whether the industrial network provides the same interface at all entry and exit points of the 5G system or not, and (iii) the utilization of cloud resources, i.e. whether the industrial application outsources functions to the 5G system or not.

As an assumption, this paper considers the integration into a homogeneous network and does not explicitly deal with cloud aspects. The resulting scenario is shown in [figure 1](#).

2 Mobile Network Integration

Most often, the mobile network has to be integrated into an existing industrial infrastructure. As a general trend, technologies used in Local Area Networks (LAN) are further developed to make them fit for industrial applications, in particular with regard to physical robustness and high availability. At Layer 1 (Physical Layer) and Layer 2 (Data Link Layer) of the well-known OSI model, Ethernet has evolved as the de-facto standard. While the Internet Protocol (IP) is clearly the protocol of choice at the Layer 3 (Network Layer) for building Local Area and Wide Area Networks (WAN), this doesn't hold true for all industrial networks. In the following we will show how mobile network technologies fit into the industrial environment, based on a Layer 3 (IP) approach or based on a Layer 2 (Ethernet) approach.

2.1 Integration approach on layer 3

In this section we assume that IP is used as the common Layer 3 throughout the network. The 4th generation of mobile network technologies – LTE – is ideally suited to that approach. Due to its maturity and commercial availability of equipment, LTE is the technology of choice for building mission-critical industrial broadband networks today. It should be noted that the Layer 3 approach will be supported by 5G as well.

A Private LTE network follows the 3GPP standards as any public LTE network. The main functional blocks and interfaces are shown in [figure 2](#).

The LTE Radio Access Network (RAN) contains the Base Station(s), also known as eNodeB (eNB). The User Equipment (UE) connects to the Base Stations through the LTE air interface (Uu).

The Mobility Management Entity (MME) is the control plane (C-plane) functional element in the LTE Core Network (EPC). The MME manages and stores the User Equipment (UE) context, generates temporary identities and allocates them to UEs, authenticates the user, manages mobility and bearers, and is the termination point for Non-Access Stratum (NAS) signaling.

The Serving Gateway (S-GW) is the user plane (U-plane) gateway to the RAN. The S-GW serves as an anchor point both for inter-eNB handover and for intra 3GPP mobility, i.e. handover to and from 2G or 3G.

The Packet Data Network Gateway (P-GW) is the U-plane gateway to another network, in our case to the industrial network. The P-GW is responsible

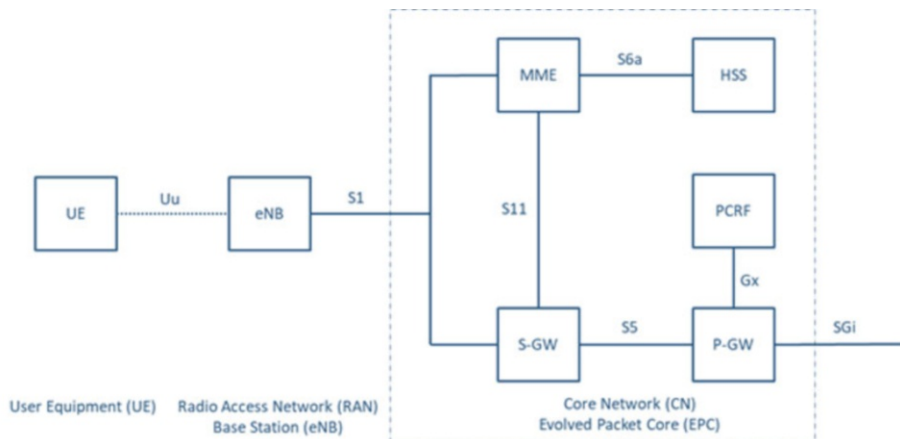

Fig. 2. LTE network architecture

for policy enforcement, charging support, and UE’s IP address allocation. It also serves as a mobility anchor point for non-3GPP access.

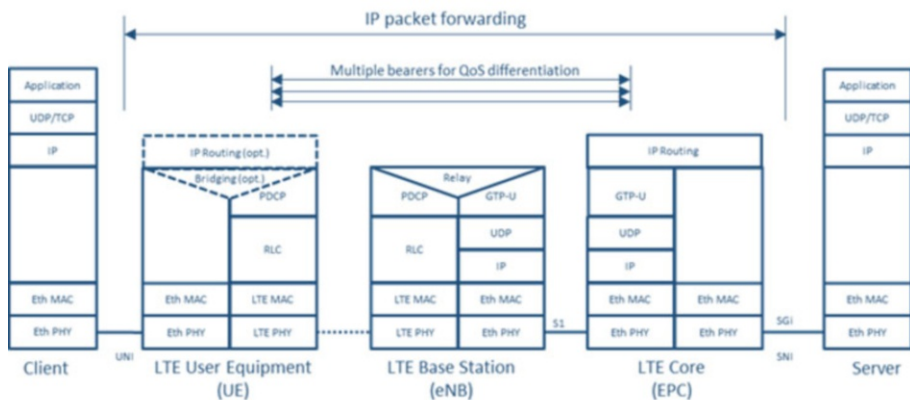

Fig. 3. LTE U-plane protocol stacks

Base Stations can be connected to each other via the X2 reference point and connected to MMEs and S-GWs via the S1-MME/S1-U reference points. A single Base Station can be connected to multiple MMEs, multiple S-GWs and multiple adjacent Base Stations.

Now, let’s assume a typical client-server model where the client application is connected to the LTE UE via a User Network Interface (UNI) and the server

application is connected to the LTE Core via a Service Network Interface (SNI), see [figure 3](#).

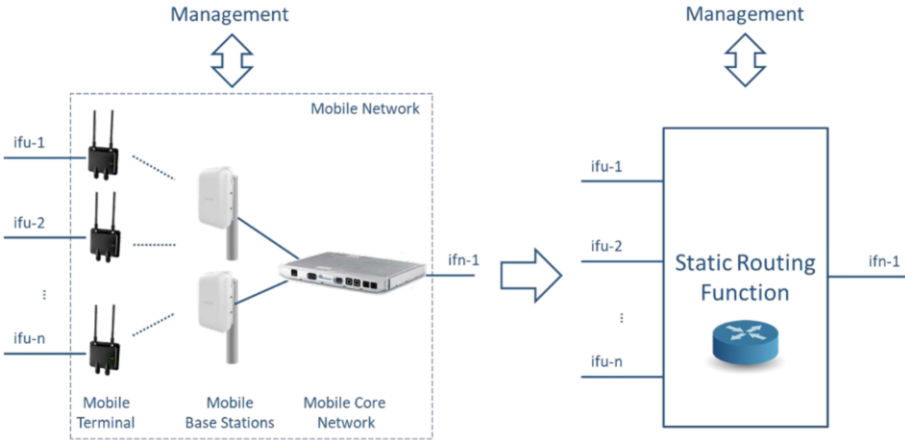

Fig. 4. LTE network modeled as an IP router

Without going into the details of the protocol stacks of the LTE network elements, it should be noted that the LTE Network can be modeled as a static IP routing function. That means, IP packets are forwarded within the LTE User Plane (U-plane) between the UNI and SNI. The SNI coincides with the LTE SGI interface. For the sake of simplicity, only one UNI and one SNI are shown. Based on this simple model, illustrated in [figure 4](#), the integration into an existing IT infrastructure is straightforward.

Regarding QoS, LTE supports QoS differentiation through so-called Bearers, see [figure 2](#). Apart from the Default Bearer, which is always present between a UE and the EPC while a UE is attached to the network, a UE may terminate one or more Dedicated Bearers. The QoS parameters of a Dedicated Bearer are defined by a QoS Class Identifier (QCI), controlling the bearer-level packet forwarding such as admission thresholds and scheduling weights.

The Differentiated Services model (DiffServ) is applicable for the Layer-3 abstraction model. DiffServ utilizes the Differentiated Services Codepoint (DSCP) of the IP header in order to classify packets regarding their per hop forwarding behavior, for example Expedited Forwarding, Assured Forwarding or Best Effort. This behavior can be easily mapped on the bearers of the mobile network. In contrast to the Integrated Services model (IntServ), DiffServ does not consider a network-wide planning for end-to-end links through a network. Therefore there is no guaranteed QoS comming with DiffServ, which is therefore also called soft QoS. In terms of industrial networks, only very low real-time requirements can be fulfilled.

An alternative approach to control the QoS in an IP network is to define Service Data Flows (SDF). Service Data Flows may be identified by source and destination IP address, the Layer-4 protocol ID and, if present depending on the protocol, source and destination Layer-4 port number, forming a 5-tuple. The mapping between Service Data Flows and Dedicated Bearers is determined by filters, more specifically the SDF Template and Traffic Flow Template (TFT). The UL-TFT in the UE classifies the traffic and selects the appropriate uplink bearer, while the DL-TFT in the EPC does the same for the downlink traffic.

2.2 Integration approach on layer 2

This sections describes an approach to transparently integrate a 3GPP 5G mobile network with a TSN-enabled Ethernet network. The TSN specifications allow three fundamental configuration models, (i) fully distributed model, (ii), centralized network - distributed user model, and (iii) fully centralized model. The models are briefly described in the following.

IEEE Time-Sensitive Networking IEEE TSN task group has evolved from the Audio Video Bridging (AVB) task group and comprises a set of specifications to provide deterministic services through IEEE 802 (particularly 802.3 Ethernet-based) networks, i.e., guaranteed packet transport with bounded low latency, low packet delay variation, and low packet loss. Currently, TSN defines three fundamental models for configuration and control of bridges and end stations.

Fully distributed model: In this model, TSN end stations, i.e. Talkers and Listeners, communicate the TSN stream requirements to a neighboring bridge, which further distributes the information in the network. Each TSN bridge on the path from Talker to Listeners propagates the TSN user and network configuration information along with the active topology for the TSN stream to the neighboring bridge(s). The network resources are managed locally in each TSN bridge, i.e., there is neither a Centralized Network Configuration (CNC) entity nor any entity that has the knowledge of the entire TSN network.

Centralized network and distributed user model: In this model, TSN end stations communicate the TSN stream requirements directly to the TSN network. In contrast to the fully distributed model, the TSN stream requirements are forwarded to a Centralized Network Configuration (CNC) entity. The TSN bridges provide information on performance capabilities and active topology to the CNC. Consequently, the CNC has a complete view of the TSN network and is therefore enabled to compute respective end-to-end communication paths from a Talker to one or multiple Listeners such that the TSN stream requirements as provided by the end stations are fulfilled. The computation result is provided by the CNC as TSN configuration information to each TSN bridge in the path between involved Talkers to the Listeners.

Fully centralized model: The fully centralized model is depicted in [Figure 5](#). It operates similar to the centralized network and distributed user model. The major difference is that a TSN end station's stream requirements are not

propagated throughout the network, but to a Centralized User Configuration (CUC) entity. The CUC may adapt these TSN end station stream requirements before forwarding them to the CNC. The CNC performs the same actions as described in the centralized network/distributed user model, except that CNC sends specific TSN configuration information also to the CUC. From this, the CUC may derive the TSN configuration information for the TSN end stations and notify them accordingly.

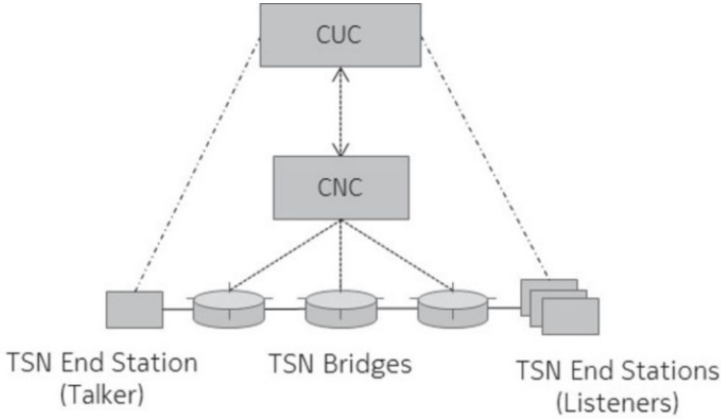

Fig. 5. Fully centralized configuration model as defined by IEEE TSN task group.

The abstraction model for integrating the 3GPP 5G system with TSN, as proposed in the following subsection, assumes configuration model (iii), but also preserves compatibility with the other two models.

Transparent integration of 3GPP 5GS with TSN – the Bridge model

In order to support the transparent integration between TSN and 3GPP mobile network domains the 3GPP mobile network as a whole needs to appear towards TSN management entities as a “conventional” TSN entity, i.e. TSN bridge. Such integration approach imposes the need for introduction of additional functions which can perform the adaptation of procedures and protocols between TSN and 3GPP network domains. [Figure 6](#) shows the functional view of integrating a 3GPP mobile network and TSN network in a transparent way.

The newly introduced functions namely TSN Translator and Adaptation Interface (AIF) are responsible for translation of protocols between TSN and 3GPP network domains. The procedures and actions from TSN are translated into according procedures and actions in the 3GPP network, and vice versa. E.g., the topology discovery within TSN may result in setting up the PDU sessions in 3GPP mobile network. On the other hand, the 3GPP network specifics such as QoS capabilities are translated into the QoS notion applicable in TSN.

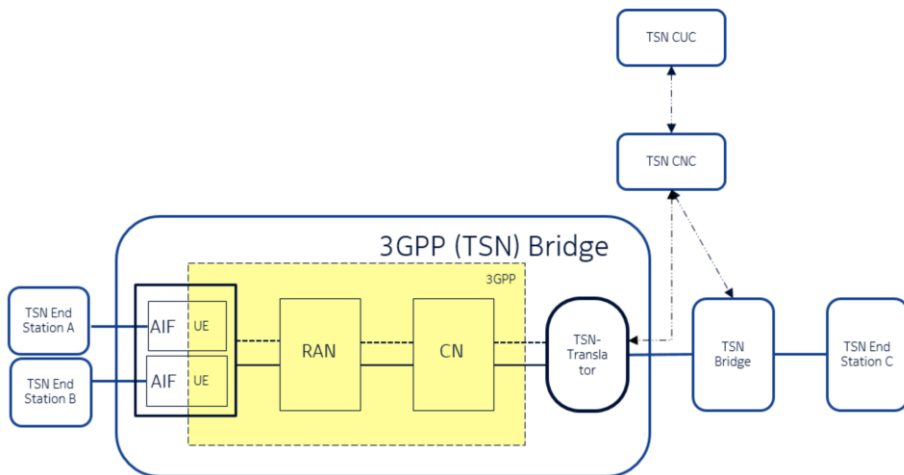

Fig. 6. *3GPP Bridge* - Modeling the 3GPP mobile network as a TSN bridge.

Furthermore, the TSN Translator and Adaptation Interface take part in execution of all the protocols needed for the operation of TSN, such as Link Layer Discovery Protocol (LLDP) and Precision Time Protocol (PTP). As an outcome the TSN Translator and the Adaptation Interface abstract the complexity of the 5G network towards TSN entities and enable the entire 5G network to appear as a TSN bridge (also referred to as 3GPP bridge) [ea18].

This facilitates the interaction between TSN and 3GPP network, as the interaction can be performed in conventional manner defined in IEEE 802.1Q specifications [IEE17]. In such a way the 3GPP network provides wireless connectivity service to the TSN network in a transparent way. However, in order to appear as a common TSN bridge towards the TSN management entities, i.e. CNC the 3GPP bridge needs to expose the same set of parameters as any other TSN bridge. In the process of network discovery the TSN CNC acquires the information about the network topology as well as capacity and capability of bridges. The attributes acquired during this procedure which are related to bridge delay are of particular importance for functionality of the integrated TSN-3GPP network. The bridge delay is described via four attributes which express the delay of frames (independent and dependent of the frame length) passing through the TSN bridge. The four bridge delay attributes are:

1. independentDelayMin,
2. independentDelayMax,
3. dependentDelayMin,
4. dependentDelayMax

The independentDelayMin/Max represents the frame length independent delay for forwarding the frame between ingress and egress port for a given traffic class. On the other hand, the dependentDelayMin/Max relates to the size of a frame to be transmitted. This delay includes the time to receive and store the frame which depends on the link speed at the ingress port.

In order to acquire correct information about capabilities of 3GPP bridge and consequently to correctly establish the E2E communication across TSN and 3GPP networks it is of great importance to correctly derive the delay attributes of 3GPP bridge. Furthermore, the exposure of delay attributes towards the TSN CNC needs to be done according to TSN protocols, in order to achieve transparent integration of 3GPP bridge. Based on TSN specifications the TSN CNC expects that the bridge delay is expressed through the values that are dependent and independent of the frame length, i.e. independentDelayMin/Max values and dependentDelayMin/Max values.

Status of 3GPP 5G system support for Time-Sensitive Networking

Currently, the 3GPP 5G specifications do not support the TSN-specific notion of frame length dependent delay. In 3GPP 5G mobile networks, the delay that packet experiences is expressed by the packet delay budget attribute defined for each QoS flow of a PDU session and its associated 5QI (5G QoS Identifier) value [3GP18b]. The 3GPP standardizes a set of 5QI values and corresponding parameters that describe each 5QI class. This information is provided in the Table 2.2 which lists the standardized 5QI values along with according QoS characteristics mapping [3GP18b]. Standardized 5QI values imply one-to-one mapping to QoS characteristics in terms of resource type, priority level, packet delay budget, packet error rate, default maximum data burst volume. Other entries of the Table 2.2 are intended for providing the information on default averaging window values, as well as providing the information on example services that can be supported by indicated 5QI value.

Therefore, there is a need of mapping between the delay attributes of 3GPP network and the delay attributes of a TSN bridge. Such mapping functionality can be incorporated into the TSN Translator. The mapping needs to take into account the QoS attributes available in the 3GPP network, such as Packet Delay Budget (PDB), Maximum Data Burst Volume (MDBV), guaranteed bit rate (GBR), etc. [3GP18b] to derive the frame size dependent and independent delay attributes of a TSN bridge.

Beyond these enhancements with respect to the QoS framework, 3GPP Working Groups have defined further study items for 5G enhancements pertaining to time-sensitive communications. An overview of selected 3GPP Rel-16 study items is depicted in [Table 1](#).

In particular, 3GPP's RAN2 working group is in the process of defining a "Study on NR Industrial Internet of Things (FS_NR_IIOT)" [3GP18e], which, among others, shall study Time Sensitive Networking related enhancements to 5G New Radio (NR). Objectives of this study include:

Table 1. Selected 3GPP Rel-16 study items relating to time-sensitive communications

Study Item	Responsible 3GPP Working Group
5GS Enhanced support of Vertical and LAN Services	SA2 [3GP18a]
Enhancement of URLLC supporting in 5GC	SA2 [3GP18c]
New Radio (NR) Industrial Internet of Things	RAN2 [3GP18e]
Physical layer enhancements for NR ultra-reliable and low latency case (URLLC)	RAN1 [3GP18d]

- Accurate reference timing: Delivery and related processes (e.g., system information block delivery or RRC delivery to UEs, multiple transmission points);
- Enhancements (e.g. for scheduling) to satisfy QoS for wireless Ethernet when using TSN traffic patterns as specified in [TR22.804];
- Ethernet header compression: (i) Analysis of the benefits and the scenario (e.g. what are the formats and size of Ethernet frame to be considered, are VLAN fields included, protocol termination etc.), (ii) Definition of the requirements for a new header compression;
- Performance evaluation of TSN requirements which are not evaluated as part of “Study on physical layer enhancements for NR ultra-reliable and low latency case” (cf. Table 1)

In summary, 3GPP’s Release 16 will introduce several additional features that will improve the support of and integration of mobile networks with TSN-enabled Ethernet networks.

3 Evaluation approach

Like all newly developed methods, the integration approaches shall be evaluated how they match the specified requirements. A proof of concept (POC) represents an early stage of this evaluation process. The POC is a well defined procedure to determine feasibility and the technical result of a concept by simulation or measurements at prototype implementations in a relevant environment. A POC provides information whether a concept is applicable at all, how well and to which extent it will work and thus becomes a basis for decisions about the further development.

For the 5G mobile networks integration into industrial networks approaches, the evaluation shall be done from the perspective of the industrial user application, which implies the evaluation at an end-to-end level. Data plane aspects and control and management plane aspects of the resulting overall network will be considered separately. This section proposes metrics for the first step of evaluation.

Table 2. Standardized 5QI to QoS characteristics mapping [3GP18b].

5QI Value	Resource Type	Default Priority Level	Packet Delay Budget	Packet Error Rate	Default Maximum Data Burst Volume	Default Averaging Window	Example Services	
10	Delay Critical GBR	11	5 ms	10^{-5}	160 B	TBD	Remote control (see TS 22.261 [2])	
11		12	10 ms	10^{-5}	320 B	TBD	Intelligent transport systems	
NOTE 4		12	20 ms	10^{-5}	640 B	TBD		
16		18	10 ms	10^{-4}	255 B	TBD	Discrete Automation	
NOTE 4		19	10 ms	10^{-4}	1358 B	NOTE 3	Discrete Automation	
17	GBR NOTE 1	20	100 ms	10^{-2}	N/A	TBD	Conversational Voice	
NOTE 4		2	40	150 ms	10^{-3}	N/A	TBD	Conversational Video (Live Streaming)
1		3	30	50 ms	10^{-3}	N/A	TBD	Real Time Gaming, V2X messages Electricity distribution – medium voltage, Process automation – monitoring
2		4	50	300 ms	10^{-6}	N/A	TBD	Non-Conversational Video (Buffered Streaming)
3		65	7	75 ms	10^{-2}	N/A	TBD	Mission Critical user plane Push To Talk voice (e.g., MCPTT)
4		66	20	100 ms	10^{-2}	N/A	TBD	Non-Mission-Critical user plane Push To Talk voice
5		75	25	50 ms	10^{-2}	N/A	TBD	V2X messages
6		E	18	10 ms	10^{-4}	255 B	TBD	Discrete Automation
7		NOTE 4	19	10 ms	10^{-4}	1358 B	NOTE 3	Discrete Automation
8		F	19	10 ms	10^{-4}	1358 B	NOTE 3	Discrete Automation
9		NOTE 4	5	100 ms	10^{-6}	N/A	N/A	IMS Signalling
10		Non-GBR NOTE 1	6	300 ms	10^{-6}	N/A	N/A	Video (Buffered Streaming) TCP-based (e.g., www, e-mail, chat, ftp, p2p file sharing, progressive video, etc.)
11			7	100 ms	10^{-3}	N/A	N/A	Voice, Video (Live Streaming) Interactive Gaming
12			8	300 ms	10^{-6}	N/A	N/A	Video (Buffered Streaming) TCP-based (e.g., www, e-mail, chat, ftp, p2p file sharing, progressive video, etc.)
13			9	90		N/A	N/A	sharing, progressive video, etc.)
14	69		5	60 ms	10^{-6}	N/A	N/A	Mission Critical delay sensitive signalling (e.g., MC-PTT signalling)
15	70		55	200 ms	10^{-6}	N/A	N/A	Mission Critical Data (e.g. example services are the same as QCI 6/8/9)
16	79		65	50 ms	10^{-2}	N/A	N/A	V2X messages
17	80		66	10 ms	10^{-6}	N/A	N/A	Low Latency eMBB applications Augmented Reality

3.1 Metrics for the performance evaluation

Quality of Service (QoS) provision and assurance are highly relevant for the performance evaluation. At data plane level, a basic set of performance indicators for industrial communication are standardized in IEC 61784. Examples of them are delivery time, synchronization accuracy, throughput of real-time data, and bandwidth for non-real-time data. The authors of [DMW⁺17] extend this list by reliability and set it in relation to the packet error rate (PER) of a network.

Also the capabilities in functional safety and security can become important for industrial networks.

The quantified requirements to the performance indicators are widely different over the range of application and use cases in industrial communication. This is shown for the examples of a printing machine, a machine tool and a packaging machine in [DMW⁺17]. Additional examples and a proposal to define requirements profiles for industrial wireless applications are given in [LR16]. Considering the diversity of requirements makes obvious, that the evaluation shall be done specific to an use case and its results will be valid for this use case only.

3.2 Metrics for the usability evaluation

The usability evaluation mainly addresses the control and management plane of the network architecture resulting from the integration. Here, an emphasis is given to the practicability of control operations like configuration and monitoring in the phase of engineering and setup as well as during the operational phase. The following qualitative characteristics are essential:

- Share of manual effort: The start-up as well as changes and maintenance of the hybrid network does not increase the manual effort;
- Number of user interaction points: Preferably there is a single user interface of the hybrid network;
- Autonomous interaction between tools: There are specified interfaces for exchange of control and management information between the network technologies and they are used timely;
- Responsiveness to changes in network conditions: The resulting network is able to detect and to react on changed network conditions like poor link quality or new topology;
- Responsiveness to changes in application requirements: The resulting network is able to detect and to react on modifications in the application like changed QoS of logical links or introducing additional network nodes.

Usability also comprises the operator model of the resulting hybrid network. Procedures and the question of warranty may become complicated in case of a distributed ownership of network resources.

4 Conclusion

In this paper, two different models to integrate 5G mobile networks into homogeneous, Ethernet-based industrial networks are discussed. The first model works on layer 3 of the OSI model and integrates LTE into an IP based network as a static routing function. This approach is of comparatively low complexity and limited in fulfilling industrial requirements such as hard real-time. The second model integrates a 5G network into a TSN capable network as a TSN bridge. This approach needs more effort in exposing and mapping of protocol attributes

for the configuration but enables a transparent and efficient coupling. The evaluation of the concepts shall be done from a industrial application perspective and specific to the use case. Performance indicators and quantified requirements are available in the literature.

References

- [3GP18a] 3GPP. TR 23.724 v0.2.0, Study on enhancement of 5GS for Vertical and LAN Services, Release 16, September 2018. [Online; accessed September 27, 2019].
- [3GP18b] 3GPP. TS 23.501 v15.3.0, System Architecture for the 5G System, Release 15, September 2018. [Online; accessed September 27, 2019].
- [3GP18c] 3GPP TR 23.725 v1.0.0. Study on enhancement of Ultra-Reliable Low-Latency Communication (URLLC) support in the 5G Core network (5GC), Release 16, September 2018. [Online; accessed September 27, 2019].
- [3GP18d] 3GPP TR 38.824 v0.0.1. Study on physical layer enhancements for NR ultra-reliable and low latency case (URLLC), Release 16, September 2018. [Online; accessed September 27, 2019].
- [3GP18e] 3GPP TR 38.825 v0.0.0. Study on NR industrial Internet of Things (IoT), Release 16. http://www.3gpp.org/ftp/tsg_ran/tsg_ran/TSGR_81/Docs/RP-182090.zip, September 2018. [accessed September 27, 2019].
- [5G 18] 5G Alliance for Connected Industries and Automation (5G-ACIA), a Working Party of ZVEI. 5G for Connected Industries and Automation. <http://http://www.5g-acia.org/publications/5g-for-connected-industries-and-automation-white-paper/>, April 2018. [Online; accessed September 27, 2019].
- [DMW⁺17] S. Dietrich, G. May, O. Wetter, H. Heeren, and G. Fohler. Performance indicators and use case analysis for wireless networks in factory automation. In *2017 22nd IEEE International Conference on Emerging Technologies and Factory Automation (ETFA)*, pages 1–8, Sept 2017.
- [ea18] Rakash SivaSiva Ganesan et al. Transparent integration of 3GPP mobile network in TSN networks. In *Keynote IEEE International Conference on Communications, ICC 2018*, May 2018.
- [Fac17] Fachausschuss Funksysteme in der Informationstechnischen Gesellschaft im VDE. VDE Positionspapier Funktechnologien für Industrie 4.0. http://www.industrialradio.de/Attachments/Funktechnologien_Industrie_4.0_Web.pdf, June 2017. [Online; accessed September 27, 2019].
- [GSS⁺18] M. Gundall, J. Schneider, H. D. Schotten, M. Aleksy, D. Schulz, N. Franchi, N. Schwarzenberg, C. Markwart, R. Halfmann, P. Rost, D. Wübben, A. Neumann, M. Dingen, T. Neugebauer, R. Blunk, M. Kus, and J. Griefsbach. 5G as Enabler for Industrie 4.0 Use Cases: Challenges and Concepts. In *23rd IEEE International Conference on Emerging Technologies and Factory Automation (ETFA 2018)*, Torino, Italy, Sep 2018.
- [IEE17] IEEE P802.1Qcc. Standard for Local and Metropolitan Area Networks—Media Access Control (MAC) Bridges and Virtual Bridged Local Area Networks Amendment: Stream Reservation Protocol (SRP) Enhancements and Performance Improvements, October 2017. [Online; accessed September 27, 2019].

- [LR16] André Gnad Marko Krätzig Lutz Rauchhaupt, Darina Schulze. Anforderungsprofile im ZDKI, Version 1.1. Technical report, Begleitforschung zur zuverlässigen, drahtlosen Kommunikation in der Industrie (BZKI), Fachgruppe 1, Oct 2016.
- [NWG⁺18] A. Neumann, L. Wisniewski, R. S. Ganesan, P. Rost, and J. Jasperneite. Towards integration of Industrial Ethernet with 5G mobile networks. In *2018 14th IEEE International Workshop on Factory Communication Systems (WFCS)*, pages 1–4, June 2018.
- [RBB⁺16] P. Rost, A. Banchs, I. Berberana, M. Breitbach, M. Doll, H. Droste, C. Mannweiler, M. A. Puente, K. Samdanis, and B. Sayadi. Mobile network architecture evolution toward 5G. *IEEE Communications Magazine*, 54(5):84–91, May 2016.
- [WSJ17] M. Wollschlaeger, T. Sauter, and J. Jasperneite. The Future of Industrial Communication: Automation Networks in the Era of the Internet of Things and Industry 4.0. *IEEE Industrial Electronics Magazine*, 11(1):17–27, March 2017.
- [YPMP17] R. Yasmin, J. Petäjäjärvi, K. Mikhaylov, and A. Pouttu. On the integration of LoRaWAN with the 5G test network. In *2017 IEEE 28th Annual International Symposium on Personal, Indoor, and Mobile Radio Communications (PIMRC)*, pages 1–6, Oct 2017.

Open Access Dieses Kapitel wird unter der Creative Commons Namensnennung 4.0 International Lizenz (<http://creativecommons.org/licenses/by/4.0/deed.de>) veröffentlicht, welche die Nutzung, Vervielfältigung, Bearbeitung, Verbreitung und Wiedergabe in jeglichem Medium und Format erlaubt, sofern Sie den/die ursprünglichen Autor(en) und die Quelle ordnungsgemäß nennen, einen Link zur Creative Commons Lizenz beifügen und angeben, ob Änderungen vorgenommen wurden.

Die in diesem Kapitel enthaltenen Bilder und sonstiges Drittmaterial unterliegen ebenfalls der genannten Creative Commons Lizenz, sofern sich aus der Abbildungslegende nichts anderes ergibt. Sofern das betreffende Material nicht unter der genannten Creative Commons Lizenz steht und die betreffende Handlung nicht nach gesetzlichen Vorschriften erlaubt ist, ist für die oben aufgeführten Weiterverwendungen des Materials die Einwilligung des jeweiligen Rechteinhabers einzuholen.

