

Cooling Wet-Pad Fan Control System of Piggery Based on Zigbee

Runtao Wang¹, Fang Yang¹, Ming Li¹, Lei Tian³, and Yu Zhang²

¹ Northeast Agricultural University Engineering Institute, Harbin,
Heilongjiang Province, P.R. China, 150030

² Northeast Forestry University Engineering Institute, Harbin,
Heilongjiang Province, P.R. China, 150040

³ Department of Agricultural and Biological Engineering,
University of Illinois, Champaign-61801, USA

Abstract. In view of the traditional faults of wire network that complex wiring and costly wired network, a set of Zigbee wireless network technology based on the temperature and humidity data acquisition and control system is designed in this paper to improve the environmental temperature control in piggery. The Zigbee system which can monitor the real-time information of temperature and humidity in piggery and provide a convenient data supports for the further temperature control synthesizes the advantages of wireless networking and self healing.

Keywords: Wet-pad, Fan, Cooling, Control system, Zigbee, Temperature, Relative Humidity.

1 Introduction

It is very important to control the ambient temperature in piggery in hot summers. Practice proves that when the temperature is higher than 30 °C, if we do not take any cooling measures, the health and production of the pig will be badly affected, such as the sows do not heat and decreased appetite; the declining of fattening pigs feed utilization rate and pigs daily gain, thus affecting the pig farm production and economic benefits. Kaiying Wang etc. [1] proves that pigs of 41kg in 29.7 ~ 35.3 °C conditions that their daily feed intake decreased by 12% than in 26.3 ~ 30.4 °C. Xinfu Zeng etc.[2] by researching the period of sows pregnancy (especially in the early periods), the high temperature is not beneficial to the maintenance of pregnancy, performs not only as the increase of the emphysema and do not delivery, but also the decrease of litter size and litter weight at birth. At present, the main use of natural ventilation and Wet-pad fan system to lower the temperature of the pigsty. Since the 1950s , American scholars began to research the Wet-pad fan cooling system, and now it has been used widely all over the world[3,4].

Wireless sensor network (WSN) as a new development direction in the field of information science, but also the results of cross-field between emerging disciplines and the traditional subjects. Domestic and foreign scholars have applied WSN in the field of agriculture[5-8]. Zigbee technology is a low cost, low power consumption network of close distance and wireless network communication technology. According to the advantages of Zigbee network, this paper designed a set of systems based on Zigbee technology of barn temperature and humidity acquisition and Wet-pad fan controlling, and stored the collecting datum of temperature and humidity in computer.

2 System Design

2.1 The Operating Principle of Wet-Pad- Ventilator

The Wet-pad cooling system mainly composed by the Wet-pad, fan, water cycle system and auto-matic control device , and the core part is Wet-pad, the principle of the system is: with high temperature the evaporation absorbs the heat in the air and trans-forms the heat into the latent heat vapor to cooling.

Figure 1 is the Wet-pad cooling schemes. A Wet-pad installed at one side of the wall, a fan crates in-stalled at the other side of the wall. The fan exhausts the air leading to negative pressure in piggery, and the outdoor air which exposing with the air in the surface of the Wet-pad is forced into the piggery through the Wet-pad, relying on the evaporation to intake the sensible heat in the air to realize the purpose of cool-ing and humidifying.

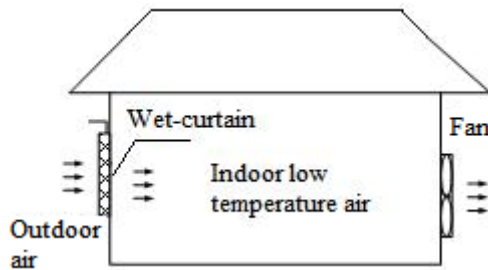

Fig. 1. Wet-pad cooling schemes

2.2 Zigbee Wireless System Structure

Zigbee is the wireless communication technology of low rate, near field, low power consumption, low complexity, low cost, reliable communications, high network capacity and such characteristics like these. The agreement made by IEEE 802.15.4 task group and Zigbee alliance, and the application layer allows according to the user's application to go on the deve-loppment [9].

As shown in figure 2, Zigbee acquisition and control system composed by the gateway node structure (coordinator), utility node (routers and end device) [10]. Coordinator is responsible for the choice of initial communications channel and the initial network configuration and accepting child nodes to join the network, and also responsible for collecting the temperature and the humidity datum which from the router and the terminal node, and through RS232 universal serial bus transmitted to PC. According to these temperature and humidity datum, the PC judges whether to open the Wet-pad fan.

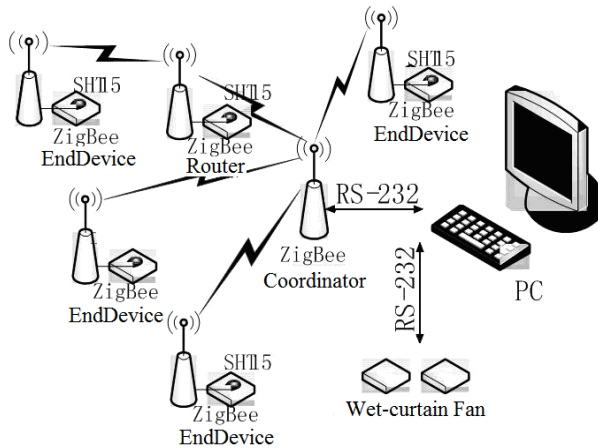

Fig. 2. Zigbee wireless system structure

2.3 System Hardware

Zigbee wireless temperature and humidity acquisition module uses CC2530 processor. CC2530 system function modules integrated RF transceiver, enhanced 8051MCU. Sleep mode current consumption only $0.9\mu\text{A}$, can use external interruption or RTC sense system: standby mode current consumption is less than $0.6\mu\text{A}$, and also can use external interruption sense system: requires a large voltage supply between 2.0V and 3.6V; Integrated with AES safety coprocessor.

Sensor module uses temperature humidity sensor module SHT15. SHT15 integrates temperature humidity sensor, the conditioning and amplifying circuit, A/D converting and I²C bus in one chip. The serial interface of SHT15 has a definite advantage both on the reading of sensor signal and power consumption. Current consumption is $550\mu\text{A}$ in measuring, $28\mu\text{A}$ in average, $3\mu\text{A}$ during sleep. Figure 3 is the SHT15 temperature and humidity sensor and CC2530 circuit diagram.

The composition of Wet-pad fan controlled by MOC3083M zero optocoupler bilateral triac driver IC, bilateral triac BTA16 and AC contactor. MOC3083M

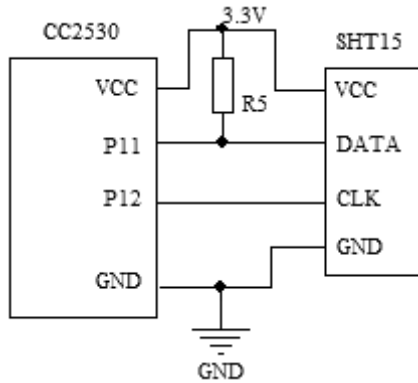

Fig. 3. SHT15 temperature and humidity sensor and CC2530 circuit diagram

contains of zero detection circuit, repeating reverse impulse voltage 800 V, LED trigger current Max 5 mA. BTA16 repetitive peak off-state voltage is 600 V, effective output current valu is 16 A. The AC contactor uses Schneider LC1-D09, the contact points are in open state, current is 25 A, compression voltage is 690 V. Figure 4 is the Wet-pad fan control diagram.

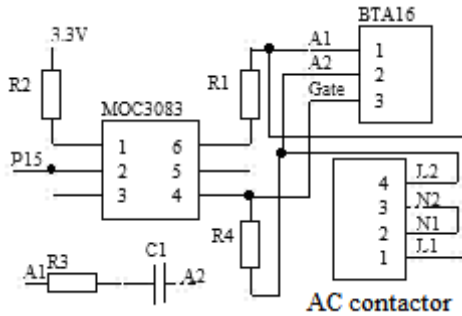

Fig. 4. The Wet-pad Fan Control Diagram

2.4 Zigbee End Device Software Design

The wireless software is based on the Z-Stack protocol Stack development of TI Company. Z-Stack Protocol Stack has compiled code for the users, the developers just contribute their attentain to the deve-lopment of application layer, eliminating the tedious work of developing the underlying protocal. Z-Stack was be given in the form of operating system, all the operations were defined as task or events.

Zigbee End Device collects the temperature and the humidity datum periodically and sending to coordina-tor, therefore, periodic wake-up model can be used, only when collecting datum and sending information are work, other times for sleep mode. Figure 5 is the program flow chart of Zigbee terminal node.

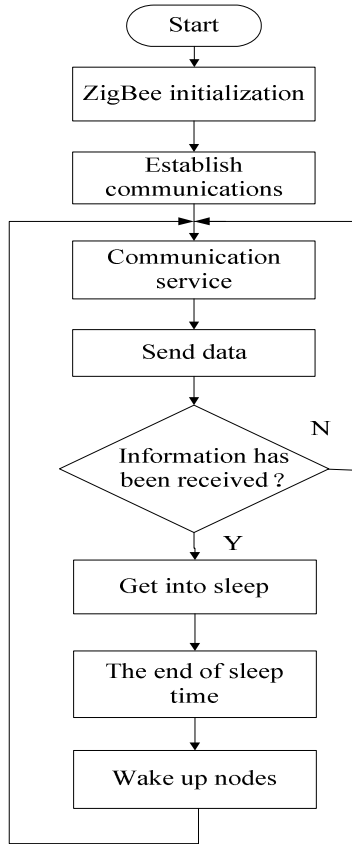

Fig. 5. The program flow chart of Zigbee terminal node

3 Test

3.1 Calculation of the Heat

The main heat produced by pigs is from the basal metabolism and other heat production, estimate the heat production is[11]:

$$Q = 293 * W^{0.75} * 1.2 \quad (1)$$

In the formula:

Q —total heat production of the pigs(kJ / d);

W —weight (kg);

293—the average heat production of metabolic weight a day per kilogram(kJ);
 1.2—the other coefficient of heat production;

According to the calculation of formula(1), the heating power of 75 pigs on 100kg is about $9.7 kW$, as the solar radiation and high temperatures outside, the heat absorbed by wall is about $5 kW$, the total heat is about $15 kW$.

3.2 Calculation on Refrigeration Capacity of the Wet-Pad-Ventilator

$$H = \frac{Q * 3600}{(t_1 - t_2) * \rho * c_p} \quad (2)$$

In the formula:

H —after washing the flow of air, (m^3 / h);

Q —sensible heat load power, (kW);

$t_1 - t_2$ —after washing the rise temperature through the piggery, ($^{\circ}C$);

ρ —the air density is $1.165 kg / m^3$ at $30^{\circ}C$;

c_p —the air heat capacity is $1.005 kJ / (kg \cdot K)$ at $30^{\circ}C$;

Good Wet-pad fan cooling system makes the dry-bulb temperature in the outside dropped slightly higher than the outside wet-bulb temperature $1\sim 2^{\circ}C$. When the outdoor temperature is $36^{\circ}C$, the relative humidity is 45%, the wet-bulb temperature is $26^{\circ}C$, the speed of the Wet-pad fan is $1.1 m / s$, when the temperature of the exhausted air is falling by $2^{\circ}C$ after washing, cooling capacity at $15 kW$, according to formula(2) can calculate out the airflow is $23061 m^3 / h$, therefore, the usage of four HangYang YWF4D-500 fans, the rated airflow of each fan is $8850 m^3 / h$, wind pressure is $190 Pa$.

3.3 The Actual Temperature and Humidity Data

Zigbee coordinator sends the temperature and humidity datum to the terminal node per minute. Figure 6 is the temperature acquisition figure of the outdoor, Wet-pad and the fan. Figure 7 is the relative humidity acquisition figure of the outdoor, Wet-pad and the fan. The average temperature of outdoor is $36.12^{\circ}C$, the average temperature of the Wet-pad is $28.42^{\circ}C$, of the fan is $30.27^{\circ}C$. The average outdoor relative humidity is 45.32%, the average humidity of the Wet-pad is 86.24%, the average humidity of the fan is 68.85%. The average temperature of the Wet-pad and the fan in piggery is $29.35^{\circ}C$, which is lower than the outdoor of $6.77^{\circ}C$.

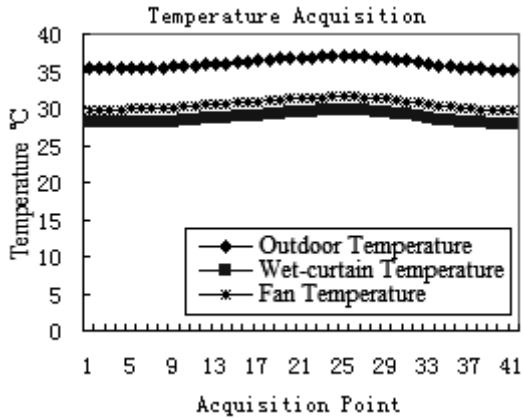

Fig. 6. Temperature Acquisition Data Chart

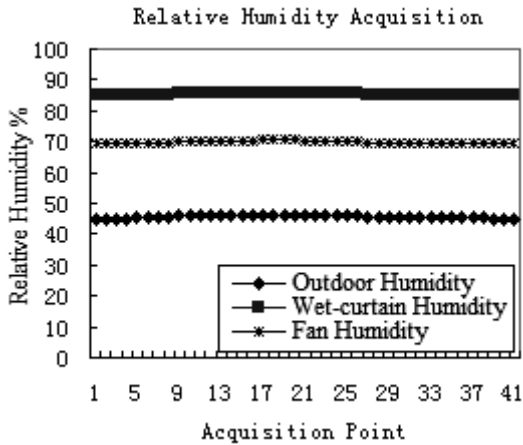

Fig. 7. The Relative Humidity Data Acquisition Chart

4 Conclusion

A set of controlling system of temperature and humidity acquisition and Wet-pad fan in piggery which combines the advantage of Zigbee's wireless networking and self healing is designed in this paper. The preliminary tests show that the system is stable, timely uploading the data of temperature and humidity. In the condition that the average outdoor temperature of 36.12°C and average relative humidity of 45.32% , the average indoor temperature is lowered to 29.35°C through the controlling of the Wet-pad fan to make the outdoor temperature lowering by 6.77°C . The system effectively reduces the temperature in the piggery and provides convenient data support for the further controlling.

References

1. Wang, K., Miao, X., Cui, S.: Effects of Ambient Temperature and Relative Humidity on Physiological Parameters and Performance of Growing Pigs. *Transactions of The Chinese Society of Agricultural Engineering* 18(1), 99–102 (2002)
2. Zeng, X., Chen, A.: Effect of Environmental Temperature on Reproductivity of Sow and Development of Piglet. *Ecology of Domestic Animal* 22(1), 40–43 (2001)
3. Yu, X., Wu, H., Liuwei: The Usage of Wet-pad Fan in Piggery. *Shanghai Journal of Animal Husbandry and Veterinary Medicine* (5), 56–57 (2005)
4. Turner Larry, W., Monegue, H.J., Gates Richard, S., et al.: Fan, sprinkler, and sprinkler plus fan systems for cooling growing—finishing swine. In: *Proceedings of the 1997 ASAE Annual International Meeting. Part 3(of 3)*, Minneapolis, MN, USA, August 10-14 (1997)
5. Morais, R., Fernandes, M.A., Matos, S.G.: A ZigBee multi-powered wireless acquisition device for remote sensing applications in precision viticulture. *Computers and Electronics in Agriculture* 62(2), 94–106 (2008)
6. Kim, Y., Evans, R.G., Iversen, W.M.: Evaluation of closed- loopsite-specific irrigation with wireless sensor network. *Journal of Irrigation and Drainage Engineering* 135(1), 25–31 (2009)
7. Kim, Y., Evans, R.G., Iversen, W.M.: Remote sensing and control of an irrigation system using a distributed wireless sensor network. *IEEE Transactions on Instrumentation and Measurement* 57(7), 1379–1387 (2008)
8. Liuhui, Maohua, W., Yuexuan, W., et al.: Development of farmland soil moisture and temperature monitoring system based on wireless sensor network. *Journal of Jilin University (Engineering and Technology Edition)* 38(3), 604–608 (2008)
9. IEEE. Std 802. 15. 4- 2003 Part 15. 4: Wire less Medium Access Control(MAC) and Physical Layer(PHY) Specifications for Low-Rate Wireless Personal Area Networks(LR-WPANs). Institute of Electrical and Electronic Engineers Inc., New York (2003)
10. ZigBee Technical Overview. ZigBee Alliance (May 2007)
11. He, C., Niu, Z., Liao, N.: Numerical Simulation in the Piggery under Vertical Ventilation. *Journal of Agricultural Mechanization Research* 8, 29–32 (2009)